



# Programming instructions

## Helpful hints

Please take the few minutes required to read the programming instructions. Experience has shown that users who do read the instructions have no difficulty in programming and using their thermostat. Then find a convenient place for the instruction manual so that you can easily refresh your memory at a later date.

## Introduction

Your new thermostat contains a microcomputer that will automatically adjust the temperature of your store or office, up to four times each day, to save money and energy. It provides comfortable heating or cooling when you need it, and reduces energy expenditure during off-business hours and vacation periods. You can program four temperatures into your thermostat. Each temperature can be selected with a different start time for each day of the week.

You can **OVERRIDE** or **SUPERSEDE** these settings whenever you wish to vary the schedule. For example employees working after hours can override the setback temperature by simply touching a button. In addition, you can keep the temperature at a constant setting for any period from one hour up to 31 days using the **TIMED OVERRIDE** feature, explained on page 9.

We also recommend that key employees read the instructions, and before installation, practice programming the thermostat by inserting the battery and following the programming steps. They will soon know how truly simple it is to operate the thermostat.

The thermostat should then be installed. We recommend that a qualified technician install the thermostat because it is very important that it is properly located and all heating and cooling circuits are wired correctly. For **INSTALLATION INSTRUCTIONS** start on page 11.

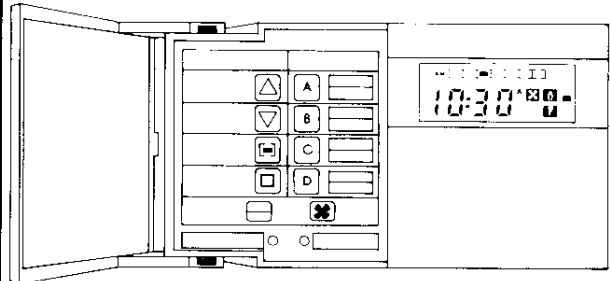

# Know your thermostat

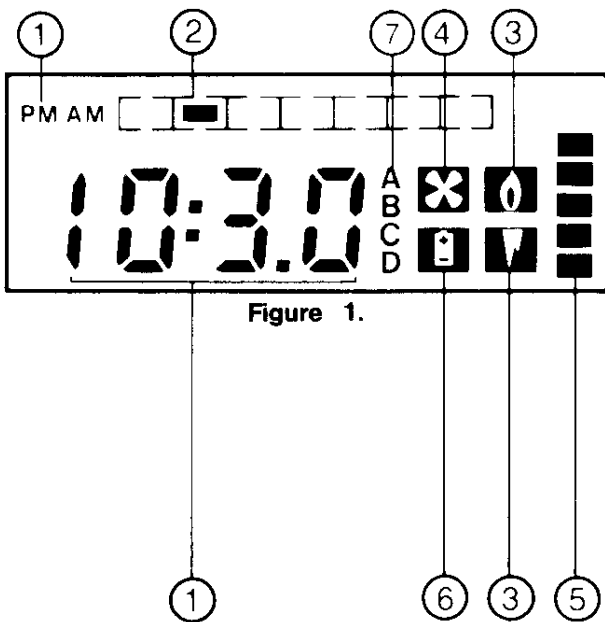

## Display

- ① The time of day AM or PM and the actual room temperature are displayed alternating at 4 second intervals in normal operation, and the decimal or colon are constantly blinking when temperature and time respectively are shown.
- ① A set temperature and time are displayed when programming. Nothing is blinking. The factory setting for all programs is shown in figure 3b on page 4.
- ① The duration of timed override is displayed. Nothing blinks. (see timed override page 9).  
Note: decimal point is displayed and not a colon as in a time display.
- ② Day of week, shows the day indicator at Monday.
- ③ Mode symbols, indicating system in cooling (icicle), heating (flame), heating and cooling (flame and icicle), emergency heat (flashing flame), or **OFF** mode (no symbols).
- ④ Fan symbol shows when the fan is in the 'on' continuous mode.
- ⑤ Indicators showing from bottom to top: 2nd stage cool, 1st stage cool, 1st stage heat, 2nd stage heat, 3rd stage heat.
- ⑥ Indicates when unit is operating on the battery (thermostat is not installed or the power is off). When battery needs to be replaced, the symbol is flashing.
- ⑦ Indicates the program A,B,C, or D in which the thermostat is operating.

## Slide switches

The slide switches 1 to 10 and the wire loop switch are accessed from the rear of the front unit of the thermostat. They have been preset at the factory for the most frequently used settings and **should only be changed by the installer.**

However, if you wish to review the options, see page 14.

Figure 2. Rear view of front unit

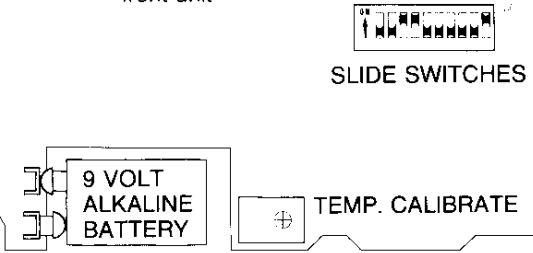

## Control buttons

There are Function buttons on the left and Program buttons on the right. Each button has multiple uses.

- Raises temperature, adjusts hours, sets override hours
- Lowers temperature, adjusts minutes, skips program -----
- Advances the day indicator to the correct day of week, sets override days when override is displayed
- Pressing once resumes program  
Pressing a second time displays timed override
- The program buttons A, B, C and D are used to gain access to programs in order to;
  - override to the program
  - change or check the program
- 
- 
- 

Functions	Programs
Raise Temp. Adjust Hrs. Set Override Hrs.	A
Lower Temp. Adjust Mts.	B
Select Day Set Override Days	C
Resume Program Display Override	D
Select	on/auto

Front view

## Selecting your heat/cool system

By consecutively pressing and releasing the button the following symbols will appear:

HEAT	AUTO	EMERGENCY	OFF	COOL
		HEAT	(no symbols)	
		(flashing)		

With no heat or cool symbols displayed, the system is off.

With the fan button , you set the fan to continuous operation (ON mode) and the fan symbol is displayed. In the 'auto' mode, no fan symbol will be displayed and the fan operates or cycles as the system demands.

Functions	Programs
Raise Temp. Adjust Hrs. Set Override Hrs.	A
Lower Temp. Adjust Mts.	B
Select Day Set Override Days	C
Resume Program Display Override	D
Select	on/auto

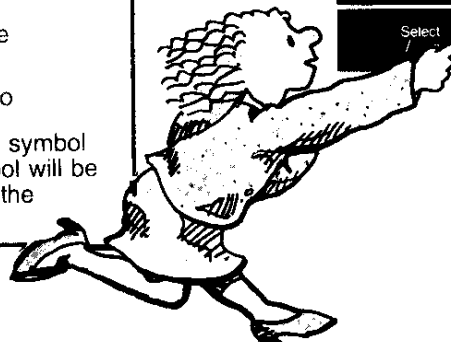

# See how to program your thermostat

## Typical office schedule

Figure 3a.

Temperature		Time AM/PM						
		Sun	Mon	Tues	Wed	Thur	Fri	Sat
A	Heat 68	----	9:00 AM	9:00 AM	9:00 AM	9:00 AM	9:00 AM	10:00 AM
	Cool 72	----						
B	Heat 70	----						
	Cool 74	----						
C	Heat 70	----						
	Cool 74	----						
D	Heat 62	10:30 PM	5:00 PM	5:00 PM	5:00 PM	9:00 PM	9:00 PM	6:00 PM
	Cool 78							

## Typical residential schedule

Figure 3b.

Temperature		Time AM/PM						
		Sun	Mon	Tues	Wed	Thur	Fri	Sat
A	Heat 68	8:00 AM	6:00 AM	6:00 AM	6:00 AM	6:00 AM	6:00 AM	8:00 AM
	Cool 73							
B	Heat 64	----	8:00 AM	8:00 AM	8:00 AM	8:00 AM	8:00 AM	----
	Cool 85							
C	Heat 68	----	3:30 PM	3:30 PM	3:30 PM	3:30 PM	3:30 PM	----
	Cool 73							
D	Heat 62	10:30 PM	10:30 PM	10:30 PM	10:30 PM	10:30 PM	10:30 PM	10:30 PM
	Cool 78							

NOTE:  
If the thermostat has more than one setting with the same start time, it chooses the first one in alphabetical order.

The first thing to do before programming the thermostat is to determine the requirements for each day as to temperature and time. Figure 3b is the factory set schedule. Until a program is entered by the user, the factory set program controls the temperature.

Figure 4 is a blank form for your use. Start by selecting your heat/cool temperatures. Now determine the times that you want the temperatures to be active on Sunday. Write in the desired times in the appropriate place. If you want to skip a temperature, write in four dashes as is done in the typical schedules. Now do the same for the remaining days of the week.

**Note:** Unlike conventional clock thermostats, this thermostat will bring the building to the required temperature at the programmed time on recovery from unoccupied periods.

*Fill in this chart to help program your schedule*

Temperature		Time AM/PM						
		Sun	Mon	Tues	Wed	Thur	Fri	Sat
A	Heat							
	Cool							
B	Heat							
	Cool							
C	Heat							
	Cool							
D	Heat							
	Cool							

Figure 4.

# Begin on page 12

## Battery installation and startup

Your microcomputer thermostat, like many modern electronic devices such as office computers, can be disrupted or damaged by static electricity. Although we have taken steps to lessen the thermostat's susceptibility to static electricity, we advise that you discharge any static build-up on your body by touching a metal object before touching your thermostat.

1. Separate the thermostat front unit from the mounting plate (page 12 figure 13).
2. Install the battery (Page 3 figure 2 shows location).
3. Allow a few seconds for the display to start flashing once per second as in figure 5.



Figure 5. Display on start-up

Press the  button and observe the time and temperature alternating every 4 seconds.

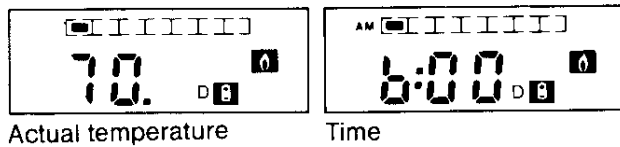

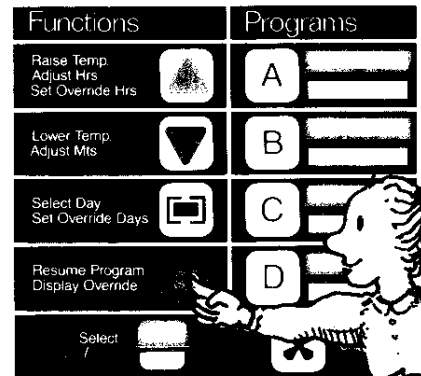

Actual temperature

Time



## STEP 2. Set correct time of day

When the display is showing time, press and hold the  button, until the hour digits advance to the correct hour, ensuring that AM/PM indicator is correct. (This button will not affect minutes).

Again when the time is displayed, press and hold  button until the minute digits advance to the correct minute. (This button will not affect the hours).

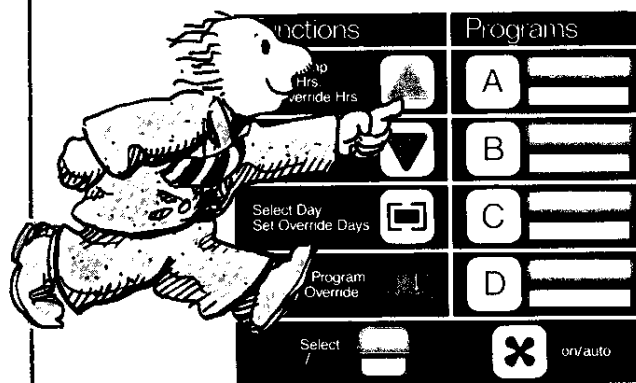

Functions	Programs
Raise Temp. Adjust Hrs. Set Override Hrs	A
Lower Temp. Adjust Mts.	B
Select Day Set Override Days	C
Resume Program Display Override	D
Select	on/e

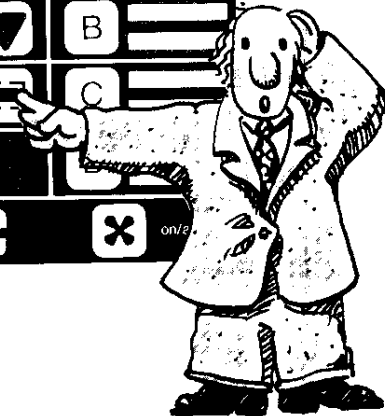

### STEP 3. Set correct day of week

Press the  button, and advance the day indicator to the correct day of the week. Figure 6 shows the indicator at Sunday.

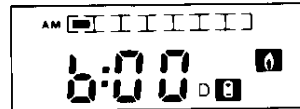
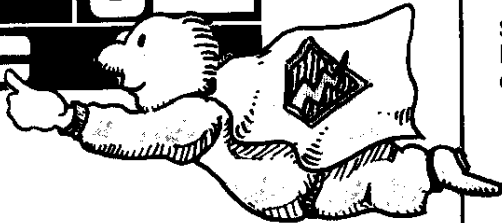



Figure 6.

Functions	Programs
Raise Temp. Adjust Hrs. Set Override Hrs	A
Lower Temp. Adjust Mts.	B
Select Day Set Override Days	C
Resume Program Display Override	D
Select	on/e







### STEP 4. Select heat/ cool system

By consecutively pressing and releasing the  button the following symbols will appear in this order on your display.

HEAT AUTO EMERGENCY OFF COOL  
  HEAT (no symbols)   
 (flashing)



Select and display your system requirements ie, heat only, cool only, or heating and cooling (auto change over).



#### NOTE

- The battery symbol will show when power is off.
- Battery symbol will flash to indicate weak battery.
- When no heat or cool symbol is displayed, the system is off.
- If you have  only or  only displayed, you will program one temperature and the time. If you have both  and  (auto change over) you will first program heat, then cool, and then the times.







For the following steps, refer to your personal schedule on page 4.

## STEP 5. Enter your A program temperatures

This sequence assumes that you selected the auto  





mode in step 4. If you have heat only  selected you will program just the heat temperature by skipping substeps (3) and (4). If you have cool only  selected

you will program just the cool temperature by skipping substeps (1) and (2).

- (1) Press and release . You will observe a display as in figure 7. This is the heat temperature.
- (2) Press  to raise or  to lower to the desired temperature.
- (3) Press and release . You will observe a display as in figure 8. This is the cool temperature.
- (4) Press  to raise or  to lower to the desired temperature.

**Note:** The thermostat's design will not allow the heat and first stage cool setpoints to be set closer than 2°F or 1°C. Second and third stage cooling control 1° and 2°F (0.5° and 1°C) above the setpoint respectively.

## STEP 6. Enter Sunday A program time

- (1) Press and release 
- (2) Press  and advance the day indicator to the left hand position (Sunday). You will see a display as in figure 9.
- (3) Press  to advance hours and  to advance minutes (10 minute increments) to the desired start time. You have now entered the Sunday A time.

### Skipping a program

When advancing the minutes between 50 and 00, you will see a display as in figure 10. This means that the program will be skipped. However, the temperatures will still be available for OVERRIDE.

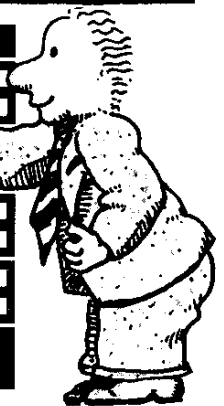
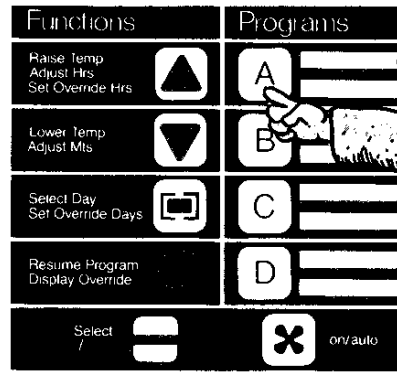

Figure 7. Heat set point



Figure 8. Cool set point

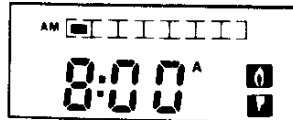
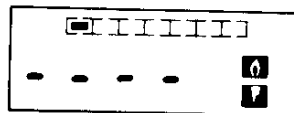
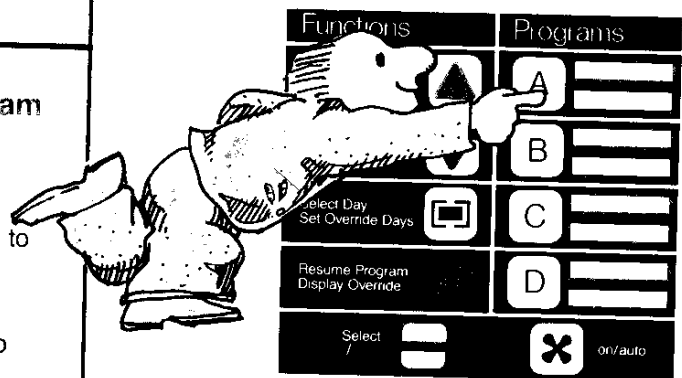

Figure 9. Time

**Note:** These displays are typical only. What you observe will differ if someone has already programmed the thermostat or if your system selection is not heat/cool (see step 4).



Push  to exit skip mode.





Figure 10. Program skipped

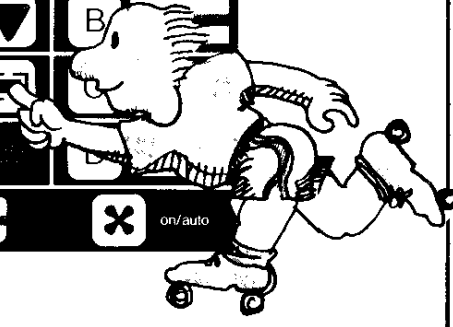

Functions	Programs
Raise Temp Adjust Hrs Set Override Hrs	A
Lower Temp Adjust Mts	B
Select Day Set Override Days	
Resume Program Display Override	
Select	on/auto







### STEP 7. Enter the A times for the balance of the week

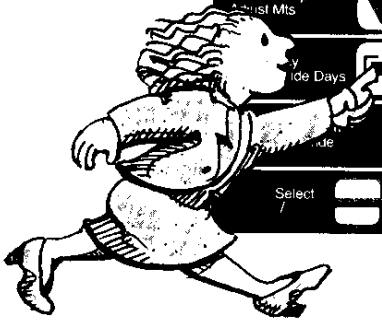



- (1) Press  to advance the day indicator to Monday.
- (2) Press  to advance hours and  to advance minutes (10 minute increments) to the desired start time.
- (3) In a similar fashion program the times for the rest of the week. by advancing the day indicator with  and repeating substep (2).

Functions	Programs
Raise Temp Adjust Hrs Set Override Hrs	A
Lower Temp Adjust Mts	B
Select Day Set Override Days	C
Resume Program Display Override	D
Select	on/auto



### STEP 8. Enter B, C, and D temperatures and times

Repeat steps 5 to 7 substituting , , or  for .

**Note:**  and  times for Saturday and Sunday are in the factory set skip mode . To get out of skip mode, press  when  is displayed. Now set the desired time.

Functions	Programs
Raise Temp Adjust Hrs Set Override Hrs	A
Lower Temp Adjust Mts	B
Select Day Set Override Days	C
Resume Program Display Override	D
Select	on/auto

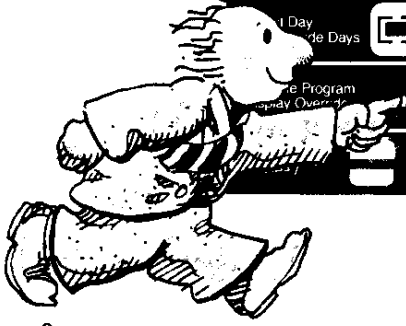

### STEP 9. Return to normal operation

Press  and the display will alternate between temperature and time and control of your environment will be automatic as programmed.

## STEP 10. Override

At any time you may override the scheduled program by merely pressing the program button **A**, **B**, **C** or **D** with the temperature you wish to hold. The display will then only show that temperature. The temperature will now control at the selected program temperature until you press **SELECT** or the override time elapses.

### Enter timed override

Note: An override time of 00.00 as in figure 11 will give a continuous override.

- (1) Press **SELECT** until you observe your display as in figure 12.
- (2) Press and hold **▲** until the desired hours of override are shown in two right digits.
- (3) Press **☐** until the desired days of override are shown.

Figure 12 shows the factory setting of 3 hours of timed override and no days. Any time the override is used, (by simply pressing

button **A**, **B**, **C** or **D** which has the desired temperature) the temperature called for will control for 3 hours and then the normal program will resume again.

Functions	Programs
Raise Temp Adjust Hrs Set Override Hrs	A
Lower Temp Adjust Mts	B
Select Day Set Override Days	C
Resume Program Display Override	D
Select	or/ auto

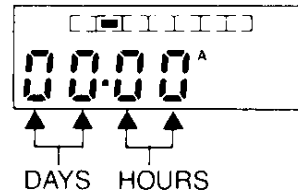

Figure 11.  
Continuous override

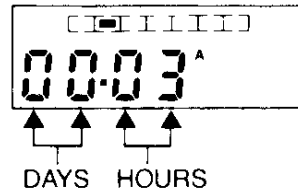

Figure 12.  
Timed override



## STEP 11. Verify Your Programs

- (1) Press **A** and check that it shows your desired heat temperature.
- (2) Press **A** again and check your cool setpoint.
- (3) Press **A** again and check your day and time.
- (4) Press **☐** **Note:** Ensure AM/PM is correct, and check your time for the following day.
- (5) Repeat (4) for each day of the week.





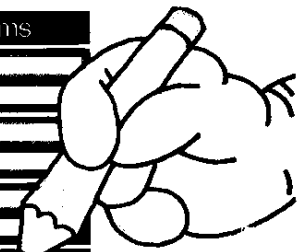





(6) In a similar manner, check your times and temperatures for B, C, and D.

Functions	Programs
Raise Temp Adjust Hrs Set Override Hrs	A
Lower Temp Adjust Mts	B
Select Day Set Override Days	C
Resume Program Display Override	D
Select	or/ auto





Write in your heat/cool temperatures in pencil.

# Using some special features

Functions	Programs
Raise Temp Adjust Hrs Set Override Hrs 	A 
Lower Temp Adjust Mts 	B 
Select Day Set Override Days 	C 
Resume Program Display Override 	D 
Select 	 on/auto



## Fan operation

To select FAN ON press . The fan will operate continuously and the fan symbol will be displayed. To select FAN AUTO, which operates the fan only when the system is running, press  a second time and the fan symbol will disappear.

## Battery symbol

The battery symbol indicates two conditions. If it is flashing, it indicates a missing or low battery condition. When this condition occurs, go to BATTERY INSTALLATION AND START-UP for instructions on how to replace the battery. If the battery symbol is displayed continuously, it indicates that the power is off and that the thermostat is maintaining its memory using the battery. A fresh battery will last 5 to 10 days without power to the thermostat. With continuous power the battery should last two to three years.

*Note:* use alkaline battery only.

## Program Lock

Keyboard buttons    

can be disabled by setting slide switch #8 ON. This prevents the program from being altered by unauthorized people.

## Smart Fan

During the occupied mode, the fan runs continuously if selected by the fan switch. In the unoccupied mode (set-up or set-back), the fan goes to AUTO.

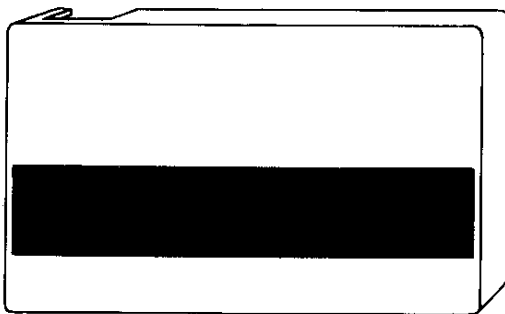

REMOTE SENSOR  
ACTUAL SIZE SHOWN

## Remote sensor Model RSK4

If you are planning on installing a remote sensor you must use a two conductor shielded and insulated cable with shield wire. Thermostat wire is not suitable for the remote sensor. Follow instructions that come with the sensor.

Suggest Belden 8760 or 8761 cable or equivalent.

# Installation instructions

- We recommend installer be a trained, experienced service technician.
- Disconnect power supply to systems before beginning installation to prevent personal injury or death from electrical shock or entanglement in moving parts and to prevent equipment damage.
- Ensure control voltage is 20-30 Vac.

## Thermostat location

To ensure proper operation, the thermostat should be mounted on an inside wall in a frequently occupied area of the building. In addition, its position must be at least 18 inches from any outside wall, and approximately five feet above the floor in a location with freely circulating air of an average temperature. Be sure to avoid the locations described below when determining a site for the thermostat.

**CAUTION- ZONE INTEGRITY MUST BE MAINTAINED TO EFFICIENTLY CONTROL UNITS OR GROUPS OF UNITS. UNLESS ZONES OF CONTROL ARE CONSIDERED AND ACCOUNTED FOR, ADJACENT UNITS MAY OPERATE IN HEATING AND COOLING MODES SIMULTANEOUSLY.**

## Do not locate the thermostat

- behind doors or in corners where freely circulating air is unavailable.
- where direct sunlight or radiant heat from appliances might affect control operation.
- on an outside wall.
- adjacent to, or in line with, conditioned air discharge grilles, stairwells, or outside doors.
- where its operation may be affected by steam or water pipes or warm air stacks in an adjacent partition space, or by an unheated/uncooled area behind the thermostat.
- where its operation will be affected by the supply air of an adjacent unit.
- near sources of electrical interference such as arcing relay contacts.

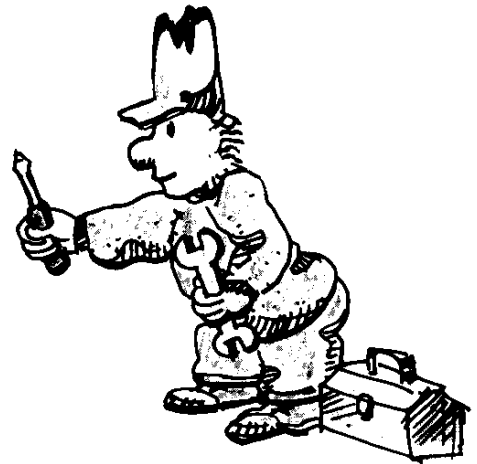

# Connecting the thermostat

Note: This thermostat requires a connection to the transformer common. Make sure that there are enough conductors in the thermostat cable to include it. A cable of up to 10 conductors may be required.

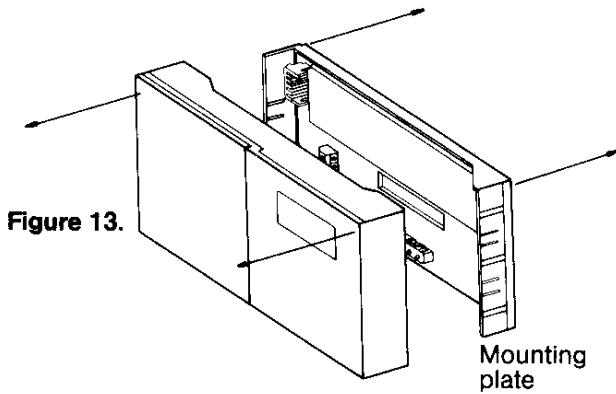

Figure 13.

1. Make sure the power to the systems is off.
2. Pull front unit off of mounting plate.
3. Determine which of the systems described in table 1 applies to your installation. See table 2 for functional descriptions of the terminals. It may be necessary to obtain schematic diagrams and other information from the heat pump manufacturer to determine installation requirements. The thermostat manufacturer may also from time to time publish wiring information.
4. Determine if and how you want to use the two general purpose indicator lights. See page 13.
5. If there are any special wiring requirements, go to the equipment and perform the wiring.
6. See table 1 below and figure 15 on page 14. Set slide switches 2, 3 and 4 to select one of the four systems. Set slide switch 7 and the wire loop switch to define terminal 6 as B, O, Y or W. Set slide switch 9 to define terminal 5 as either EH or EW. This step is very important. These slide switches must correspond to the output wiring.

Table 1

SYSTEM	OUTPUT TERMINALS									SLIDE SWITCHES		
	1	2	3	4	5	6	7	8	9	2	3	4
Single compressor	X	HP1	AUX	G	E	O/B	—	—	R	OFF	ON	ON
*Add-on single compressor	X	HP1	AUX	G	E	O/B	—	—	R	ON	OFF	OFF
Two compressor	X	HP1	AUX	G	E	O/B	HP2	—	R	ON	ON	OFF
*Add-on two compressor	X	HP1	AUX	G	E	O/B	HP2	—	R	ON	ON	ON

<table border="1"> <tr> <th>TERMINAL 5 OPTIONS</th> <th>SLIDE SWITCH 9</th> </tr> <tr> <td>EH</td> <td>OFF</td> </tr> <tr> <td>EW</td> <td>ON</td> </tr> </table>	TERMINAL 5 OPTIONS	SLIDE SWITCH 9	EH	OFF	EW	ON	<table border="1"> <tr> <th>TERMINAL 6 OPTIONS</th> <th>SLIDE SWITCH 7</th> <th>WIRE LOOP SWITCH</th> </tr> <tr> <td>O</td> <td>OFF</td> <td>OPEN</td> </tr> <tr> <td>B</td> <td>ON</td> <td>OPEN</td> </tr> <tr> <td>Y</td> <td>OFF</td> <td>CLOSED</td> </tr> <tr> <td>W</td> <td>ON</td> <td>CLOSED</td> </tr> </table>	TERMINAL 6 OPTIONS	SLIDE SWITCH 7	WIRE LOOP SWITCH	O	OFF	OPEN	B	ON	OPEN	Y	OFF	CLOSED	W	ON	CLOSED
TERMINAL 5 OPTIONS	SLIDE SWITCH 9																					
EH	OFF																					
EW	ON																					
TERMINAL 6 OPTIONS	SLIDE SWITCH 7	WIRE LOOP SWITCH																				
O	OFF	OPEN																				
B	ON	OPEN																				
Y	OFF	CLOSED																				
W	ON	CLOSED																				

\* Add-on systems turn off compressor(s) when auxiliary heat comes on.

7. Identify the wires as per your system in table 1.
8. Position the mounting plate so that all the control and indicator light wires protrude through the centrally located slot (figure 14). Level for appearance and mark the three mounting holes. Drill holes using a 3/16" (5mm) drill bit. Install supplied anchors, reposition the mounting plate and secure it to the wall. Do not overtighten screws.
9. Affix the appropriate output terminal label to your mounting plate. Connect the control wires to the proper output terminals. Connect the indicator light wires if the lights are being used.

Table 2.

OUTPUT TERMINALS	FUNCTIONAL DESCRIPTION
AUX	Energizes when auxiliary heat is required.
R	24 Vac connection for all stages.
HP1	Energizes when 1st stage compressor is required.
G	Energizes on any demand for heating or cooling or when manually activated by the fan button.
HP2	Energizes when 2nd stage compressor is required. Room temperature must be 2°F above setpoint in cooling for HP2 to energize.
O	Energizes continuously in cool mode (for reversing valve).
B	Energizes continuously in heat mode (for reversing valve).
X	24 Vac common connection.
W	Energizes on a demand for heat (energizes compressor and reversing valve).
Y	Energizes on a demand for cool (energizes compressor and reversing valve).
EH	Energizes continuously when in Emergency Heat mode.
EW	Energizes on a demand for heat when in the Emergency Heat mode.

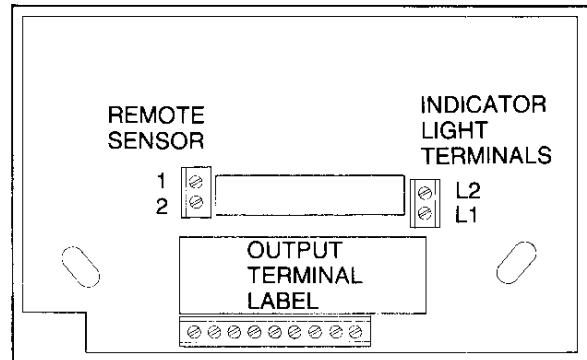
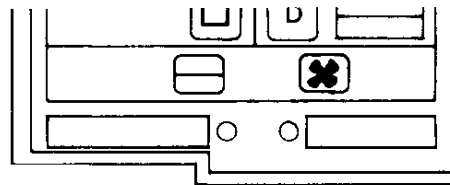

Figure 14. Mounting plate



The thermostat has two status indicator lights that can be used to indicate user defined conditions such as equipment failure, dirty filter or an output such as AUX being energized. They are activated by connecting the respective terminal (L1 for the left light and L2 for the right light) to R via an output terminal or an appropriate relay contact. For example, if AUX (terminal 3) is connected to L1, the left light will come on whenever AUX is energized. Label the lights in the area provided on the keypad using a pencil.

# Setting slide switches

10. There are a number of options that you can select with the 10 slide switches (and 1 wire loop switch). The slide switches move up and down very easily using a pen. The ON position is marked on the block that encloses the slide switches (figure 15). Set the slide switches (and wire loop switch if necessary) using the information in figure 15 as your guide. You should have already set some of these options in step 6.

**Note:**

The wire loop switch comes set in the open position from the factory. Most installations require it to be open.

Only turn on switch 8 after the thermostat is programmed.

**Switch 6**

OFF—Cycle rate of 6 cycles per hour (CPH) on auxiliary (AUX) heat.

ON—Cycle rate of 3 CPH on auxiliary heat.

Terminal 6 is:	SLIDE SWITCH 7	WIRE LOOP SWITCH
O	OFF	OPEN
B	ON	OPEN
Y	OFF	CLOSED
W	ON	CLOSED

**Switch 1**

OFF—1st stage cool cycle rate is 3 cycles per hour (CPH)  
ON—1st stage cool cycle rate is 1.5 CPH.

**Switches 2, 3 and 4** see Table 1 on page 12.

**Switch 5**

OFF—Temperature displayed in °F.  
ON—Temperature displayed in °C.

**Switch 8**

OFF—Keyboard operates normally.  
ON—These buttons are disabled to prevent program tampering:

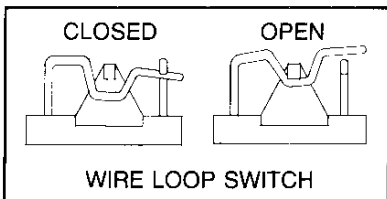

**Switch 9**

OFF—Terminal 5 is "EH".  
ON—Terminal 5 is "EW".

**Switch 10**

ON—Normal operation with internal sensor.  
OFF—For use with remote sensor.

Figure 15. Setting switches

# Battery installation & start-up

Figure 16. Start-up display

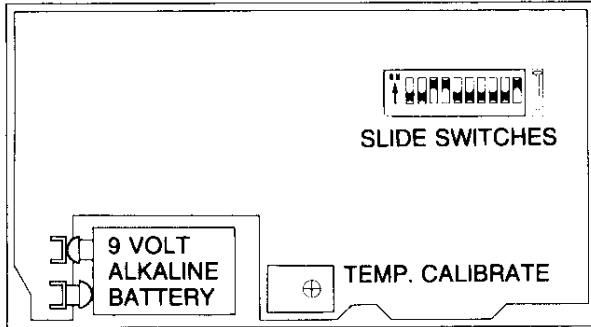
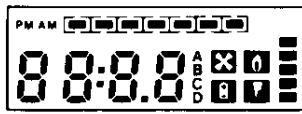

Figure 17. Rear view of front unit

## Checking installation

**CAUTION: UNIT HAS BUILT-IN TIME DELAYS FOR HEAT AND COOL. THEY MAY VARY DEPENDING ON ROOMTEMP RISE OR FALL. DELAYS CAN BE FROM 3 TO 15 MIN. PER STAGE.**

Follow the checkout procedure outlined in Table 3. When the system power is turned on the battery symbol should disappear or flash if the battery is weak or missing. Minimum on and off times have been built into the thermostat to prevent HVAC equipment damage due to short cycling. These delays may be longer than specified if the HVAC equipment has built in delays.

## Temperature Calibration

The temperature calibration control shown in figure 17 may be used for minor adjustments. Clockwise rotation will lower the displayed temperature.

11. Install the battery.
12. Allow a few seconds for the display to start flashing once per second (figure 16).
13. Push . The display will alternate every four seconds between room temperature and time.
14. Replace the thermostat front unit on mounting plate.

Table 3

STEP	PUSH BUTTON	DISPLAY SHOWS	RESPONSE
1			Heat mode
2		 	Auto heat/cool mode
3		flashing once per second	Emergency Heat mode — auxiliary stage only
4		(no symbol)	All systems go off after 7 seconds
5			Cool mode
6		select required mode (step 1,2,3 or 5) for further testing	
7		Stationary 68 or 73 (20 or 22.5)	Heating and cooling set-points. Room temperature will be maintained at these set-points
8	 	Increase or decrease of set point temperature	Equipment will respond subject to time delays
9	 hold	<b>Quick Check Start-up</b> Time delays can be reduced to a few seconds by pressing and holding any one of the program buttons A, B, C, or D. Release when the stage indicator is displayed. Care must be taken not to short cycle the compressor. Set-point should be 10° higher than ambient in heating or 10° lower than ambient in cooling. <b>Note:</b> return temperature to the original setting.	
10			Fan runs continuously
11		(no FAN symbol)	Fan operates automatically



# Trouble shooting guide

SYMPTOM	CAUSE	ACTION
UNIT APPEARS OK BUT WILL NOT ACTIVATE RELAYS OR RELAYS CHATTER	1) SOLID STATE SWITCH FAILURE 2) HIGH RESISTANCE AT EQUIPMENT	-REPLACE UNIT -LOAD DOWN RELAY COIL WITH 4700 ohm 1 WATT RESISTOR OR INSTALL ISOLATION RELAY
HEAT OR COOL STATUS INDICATORS WILL NOT APPEAR	1) BUILT IN TIME DELAYS 2) NO 24 VAC	-OVERRIDE USING QUICK CHECK START-UP -TURN ON 24 VAC
SYSTEM CYCLES BEFORE REACHING SETPOINT	BUILT IN COMPUTER RECOVERY	UNIT OPERATING NORMALLY
DISPLAY FLASHING-PROGRAM LOST	1) STATIC ELECTRICITY 2) RADIO FREQUENCY INTERFERENCE	-DISCHARGE BEFORE TOUCHING STAT! -USE SHIELDED CABLE WITH REMOTE SENSOR
TEMPERATURE READING INCORRECT	1) OUT OF CALIBRATION 2) EXTERNAL HEAT SOURCE 3) DOWN DRAFT AT THERMOSTAT	-RECALIBRATE WITH ACCURATE THERMOMETER -ISOLATE STAT FROM HEAT SOURCE OR OVERHEAD DIFFUSERS
ERRATIC TEMPERATURE READING	1) WHEN REMOTE SENSOR IS INSTALLED SWITCH #10 MUST BE OFF 2) FAULTY THERMISTOR 3) INCORRECT SHIELDING CONNECTIONS OR SHIELD GOES TO MECHANICAL GROUND	-DISCONNECT REMOTE SENSOR LEADS IF INTERNAL THERMISTOR IS TO BE USED TEMPORARILY -REPLACE OR CHECK WITH OHMMETER (10,000 ohms APPROXIMATE) -CHECK REMOTE SENSOR WIRING
STAT WILL NOT RETURN FROM SETBACK	1) OVERRIDE SET FOR DAYS 2) WRONG DAY OF WEEK	-PRESS RESUME, REMOVE DAYS FROM MEMORY -PRESS DAY KEY AND ADVANCE TO CORRECT DAY
UNIT COOLING IN HEATING MODE AND HEATING IN COOLING MODE	B/O SWITCH SET INCORRECTLY	-SEE FIGURE 15 ON PAGE 14 FOR DETAILS

---

# Specifications

---

Rated voltage	18-30 Vac
Rated current	0.050 — 1.5 Amp continuous for each output with surges to 4 Amps. Maximum 3 Amp continuous total of all outputs
Cycle rate optional optional	3 Cycles per hour 6 CPH on Auxiliary heat 1.5 CPH on 1st compressor in cooling
Minimum on/off times to prevent short cycling	1.5 CPH — 12 minutes 3 CPH — 6 minutes 6 CPH — 3 minutes
Control range Heating	42 to 114° F in 1° steps or 7 to 43° C in 0.5° steps
Cooling	44 to 116° F in 1° steps or 8 to 44° C in 0.5° steps
Temperature measurement range	38 to 119° F or 5 to 45.5° C
Accuracy	± 1° F at 68° F or ± 0.5° C at 20° C
Battery	9 volt ALKALINE (Eveready #522 or equivalent) for memory retention during power outage
Quartz clock accuracy	± 80 seconds/month
Range of ambient operation	32 to 131° F (0 to 55° C)
Storage temperature	-30 to 131° F (-34 to 55° C)
Operating humidity range	5 to 90% RH

Specifications subject to change without notice

---

## enerstat™

### Developed and manufactured by

Valera Electronics Inc.  
5370 Canotek Road,  
Ottawa, Canada K1J 9E7  
TX — 066-36589  
FAX 613-745-2743

### U.S. Marketing

Valera Corporation  
Suite 103  
Bridge and Port Authority Building  
Ogdensburg, New York 13669

### Europe

Valera Europe B.V.  
Verlaat 9  
2435 XE Zevenhoven  
Netherlands

### Southeast Asia

Valera Corporation Australia Pty. Ltd.  
37 Benwerrin Drive,  
Burwood East 3151  
Victoria, Australia  
FAX 613-233-7585