

K3-WN

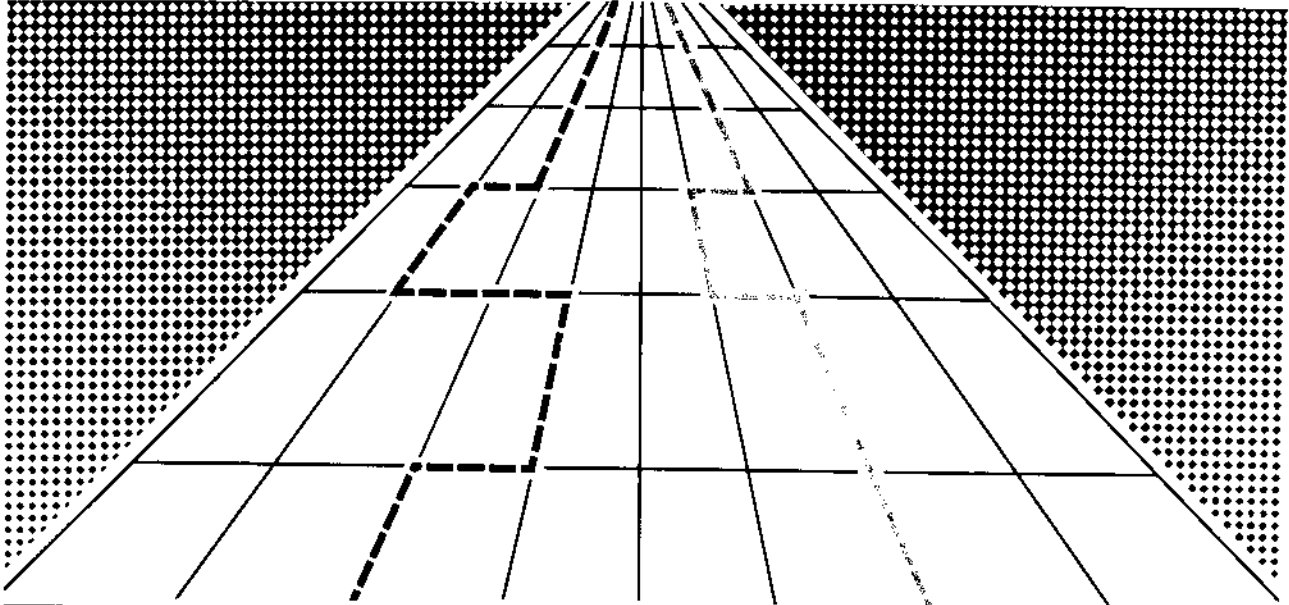

enerstatTM

Functions		Programs	
Raise Temp Adjust Hrs Set Override Hrs		A	
Lower Temp Adjust Mts		B	
Select Day Set Override Days		C	
Resume Program Display Override		D	
Select			on/off

Programmable Single Stage Heat/Cool Thermostat Model K3-WN

Index

PROGRAMMING INSTRUCTIONS

Helpful Hints	1
Introduction	1
Know Your Thermostat	2
Display	2
Slide Switches	3
Control Buttons	3
Selecting your heat/cool system	3
Set Your Personal Schedule	4
Battery Installation and Thermostat Start Up	5
Begin Programming Steps 1 to 11	5 to 9
Skipping a Program	7
Using some Special Features	10
Fan Operation	10
Battery Symbol	10
Keyboard Disable	10

INSTALLATION INSTRUCTIONS

Thermostat Location	11
Connecting Thermostat	12
Setting Slide Switches	13
Battery Installation and Start Up	14
Checking Installation	14

TROUBLE SHOOTING GUIDE

Trouble Shooting	15
Battery removal	15
Specifications	16

Warranty (inside back cover)

Programming instructions

Helpful hints

Please take the few minutes required to read the programming instructions. Experience has shown that users who do read the instructions have no difficulty in programming and using their thermostat. Then find a convenient place for your instruction manual so that you can easily refresh your memory at a later date.

Introduction

Your new thermostat contains a microcomputer that will automatically adjust the temperature of your home or office, up to four times each day, to save money and energy. It provides comfortable heating or cooling when you need it, and reduces energy expenditure while you are sleeping, or are out of the building, or on vacation. You can program four temperatures into your thermostat. Each temperature can be selected with a different start time for each of the following periods: Sunday, Weekdays, and Saturday. This weekend programming feature called 5-1-1 allows the five weekdays to have the same start times, and then allows two successive days that can each have different times.

You can **OVERRIDE** or **SUPERSEDE** these settings whenever you wish to vary the schedule. If you have guests during the evening and you do not want the temperature to drop while they are visiting, the touch of a finger to your evening setting (for example 70°F or 21°C) will **OVERRIDE** your program and keep the temperature at its current setting until after your guests have gone. In addition, you can keep the temperature at a constant setting for any period from one hour up to 31 days using the **TIMED OVERRIDE** feature, explained on page 9.

We also recommend that everyone in the family read the instructions and, before installation, practice programming the thermostat by inserting the battery and following the programming steps. You will soon know how truly simple it is to operate your thermostat.

The thermostat should then be installed. We recommend that a qualified technician install the thermostat because it is very important that it is properly located and all heating and cooling circuits are wired correctly. For **INSTALLATION INSTRUCTIONS** start on page 11.

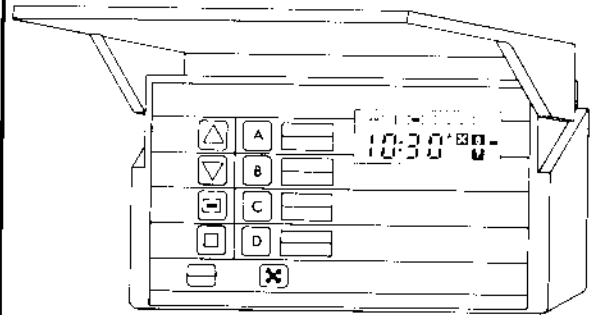

Know your thermostat

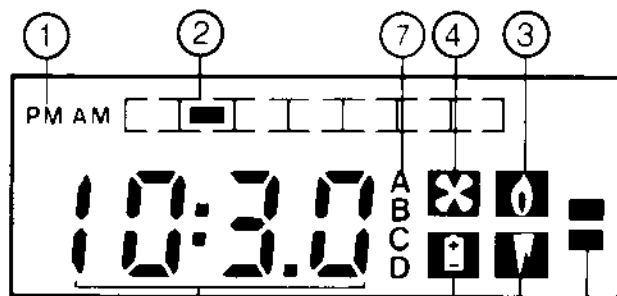

Figure 1.

Display

- ① The time of day AM or PM and the actual room temperature are displayed alternating at 4 second intervals in normal operation, and the decimal or colon are constantly blinking when temperature and time respectively are shown.
- ① A set temperature and time are displayed when programming. Nothing is blinking. The factory setting for all programs is shown in figure 3a on page 4.
- ① The duration of timed override is displayed. Nothing blinks. (see timed override page 9).
Note: decimal point is displayed and not a colon as in a time display.
- ② Day of week, shows the 'day indicator' at beginning of 5 day program, typically Monday of the 5 days of the week.
- ③ Mode symbols, indicating system in heating (flame) heating and cooling (flame and icicle) cooling (icicle) or off mode (no symbols).
- ④ Fan symbol shows when the fan is in the 'on' continuous mode.
- ⑤ Indicators showing when heating (top bar) or cooling (bottom bar) is operating.
- ⑥ Indicates when unit is operating on the battery (thermostat is not installed or the power is off). When battery needs to be replaced, the symbol is flashing.
- ⑦ Indicates the program A,B,C, or D in which the thermostat is operating.

Slide switches

The slide switches 1 to 4 are accessed from the rear of the front unit of the thermostat. They have been preset at the factory for the most frequently used settings and should only be changed by the installer.

However, if you wish to review the options, see page 13.

Figure 2. Rear view of front unit

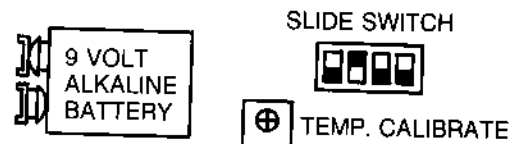

Control buttons

There are Function buttons on the left and Program buttons on the right. Each button has multiple uses.

- Raises temperature, adjusts hours, sets override hours
- Lowers temperature, adjusts minutes, skips program -----
- Push to advance the day indicator to the correct day of week, sets override days when override is displayed
- Pressing once will resume program
Pressing a second time will display timed override
- The program buttons A, B, C and D are used to gain access to programs in order to;
 - enter a program
 - override a program
 - change or check a program
-
-
-

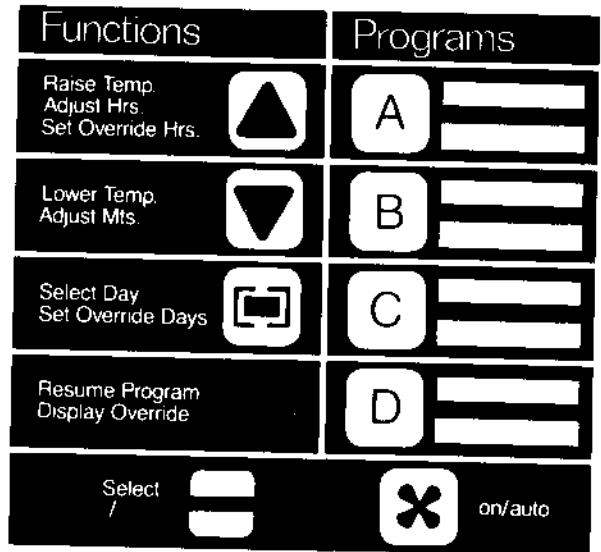

Front view

Selecting your heat/cool system

By consecutively pressing and releasing the button the following symbols will appear:

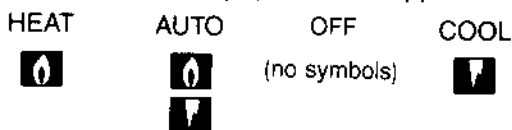

With no heat or cool symbols displayed, the system is off.

With the fan button , you set the fan to

continuous operation (ON mode) and the fan symbol is displayed. In the 'auto' mode, no fan symbol will be displayed and the fan operates or cycles as the system demands.

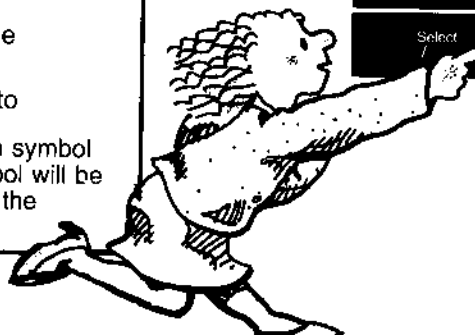
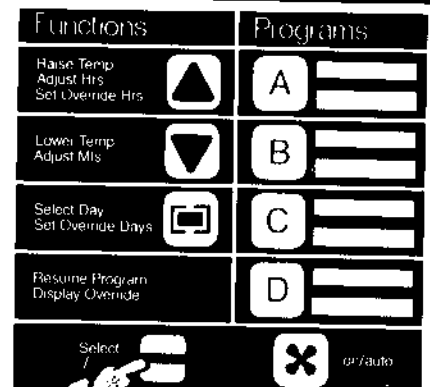

Set your personal schedule

Typical residential schedule

Figure 3a.

Temperature		Sunday Time AM/PM	Weekdays Time AM/PM	Saturday Time AM/PM
A	Heat 68	8:00 AM	6:00 AM	8:00 AM
	Cool 73			
B	Heat 64	-----	8:00 AM	-----
	Cool 85			
C	Heat 68	-----	3:30 PM	-----
	Cool 73			
D	Heat 62	10:30 PM	10:30 PM	10:30 PM
	Cool 78			

Typical office schedule

Figure 3b.

Temperature		Sunday Time AM/PM	Weekdays Time AM/PM	Saturday Time AM/PM
A	Heat 70	-----	7:30 AM	-----
	Cool 74			
B	Heat 72	-----	-----	-----
	Cool 76			
C	Heat 68	-----	-----	-----
	Cool 78			
D	Heat 60	10:30 PM	5:00 PM	10:30 PM
	Cool 82			

NOTE:
If the thermostat has more than one setting with the same start time, it chooses the first one in alphabetical order.

The first thing to do before programming your thermostat is to determine your own personal comfort levels for each day as to temperature and time. Figure 3a is the factory set schedule and it is typical of residential needs.

On the weekdays after the temperature has been lowered all night, it would be typical to have the thermostat begin to warm the house at 6:00 AM, if you get up at 7:00 AM. At 8:00 AM before everyone has left for the day, the thermostat can be set to lower the temperature to save you energy during the day. Before anyone arrives home in the afternoon, the temperature may again be increased to provide comfort for you when you return. Finally, at bedtime, the thermostat again lowers the temperature to save you energy all night.

On Saturday and Sunday when everyone is home, the temperature comes up to 68°F at 8 AM and stays there all day until 10:30 PM when the temperature sets back to 62°F. The other two temperatures are skipped, but they are still available for OVERRIDE.

Figure 4 is a blank form for your use. Start by selecting your heat/cool temperatures. Now determine the times that you want the temperatures to be active on the weekdays. Write in the desired times in the appropriate place. If you want to skip a temperature, write in four dashes as is done in the typical schedules. Now do the same for Saturday and Sunday.

NOTE: It is suggested that you set your desired program times about 1 hour before the time that you actually require your home to reach the set temperature. So if you get up at 7 AM, set the wake up temperature to come on at 6 AM.

Fill in this chart to help program your schedule

Temperature		Sunday Time AM/PM	Weekdays Time AM/PM	Saturday Time AM/PM
A	Heat			
	Cool			
B	Heat			
	Cool			
C	Heat			
	Cool			
D	Heat			
	Cool			

Figure 4.

Begin programming

Battery installation and startup

CAUTION: Your microcomputer thermostat, like many modern electronic devices such as office computers, can be disrupted or damaged by static electricity. Although we have taken steps to lessen the thermostat's susceptibility to static electricity, we advise that you discharge any static build-up on your body by touching a metal object before touching your thermostat.

1. Separate the thermostat front unit from the mounting plate (page 12 figure 13).
2. Install the battery (Page 13 shows location).
3. Allow a few seconds for the display to start flashing once per second as in figure 5.



Figure 5. Display on start-up

STEP 1.

Press the  button and observe the time and temperature alternating every 4 seconds.

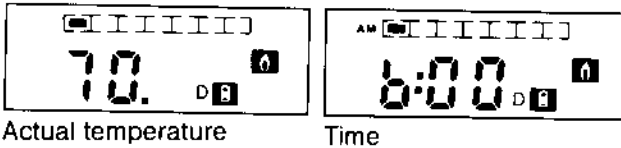

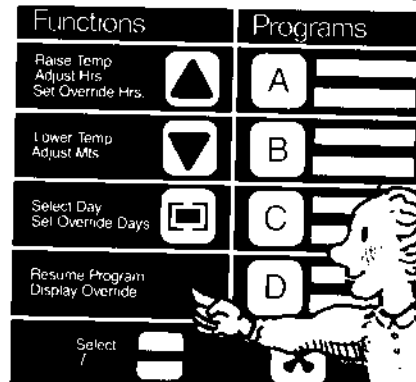

Actual temperature

Time









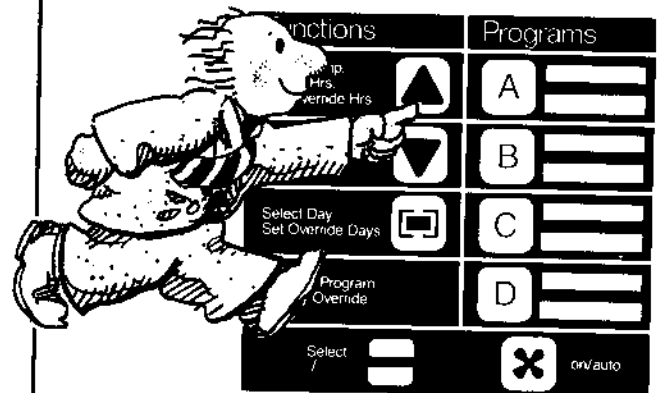



STEP 2. Set correct time of day

When the display is showing time, press and hold the  button, until the hour digits advance to the correct hour, ensuring that AM/PM indicator is correct. (This button will not affect minutes).

Again when the time is displayed, press and hold  button until the minute digits advance to the correct minute. (This button will not affect the hours).



Functions	Programs
Raise Temp. Adjust Hrs. Set Override Hrs. 	A 
Lower Temp. Adjust Mts. 	B 
Select Day Set Override Days 	C 
Resume Program Display Override 	D 
Select   on/off	

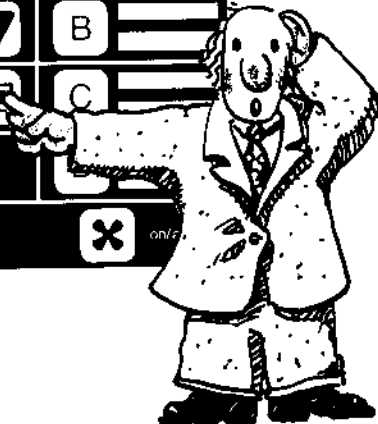

STEP 3. Set correct day of week

Press the  button, and advance the day indicator to the correct day of the week. Figure 6 shows the indicator at Sunday.

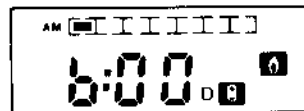









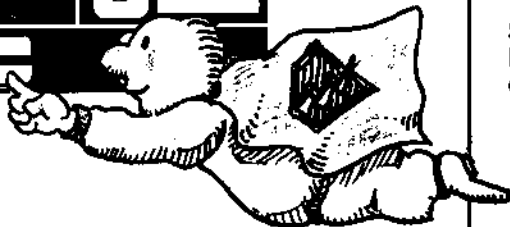







Figure 6.

Functions	Programs
Raise Temp. Adjust Hrs. Set Override Hrs. 	A 
Lower Temp. Adjust Mts. 	B 
Select Day Set Override Days 	C 
Resume Program Display Override 	D 
Select   on/off	



STEP 4. Select heat/ cool system

By consecutively pressing and releasing the  button the following symbols will appear in this order on your display.





HEAT	AUTO	OFF	COOL
		(no symbols)	
			

Select and display your system requirements ie, heat only, cool only, or heating and cooling (auto change over).

NOTE



- The battery symbol will show when power is off.
- Battery symbol will flash to indicate weak battery.

•When no heat or cool symbol is displayed, the system is off.

•If you have  only or  only displayed, you will program one temperature and the time. If you have both  and  (auto change over) you will first program heat, then cool, and then the times.

For the following steps, refer to your personal schedule on page 4.







STEP 5. Enter your A program temperatures

This sequence assumes that you selected the auto  

mode in step 4. If you have heat only 

selected you will program just the heat temperature by skipping substeps (3) and (4). If you have cool only 





selected you will program just the cool temperature by skipping substeps (1) and (2).

- (1) Press and release . You will observe a display as in figure 7. This is the heat temperature.
- (2) Press  to raise or  to lower to the desired temperature.
- (3) Press and release . You will observe a display as in figure 8. This is the cool temperature.
- (4) Press  to raise or  to lower to the desired temperature.

Note: the thermostat's design will not allow the heat and cool setpoints to be set closer than 2°F or 1°C.

Caution: We recommend that in residential use you do not have the heat and cool setpoints closer than 4°F or 2°C.

STEP 6. Enter Sunday A program time

- (1) Press and release 
- (2) Press  and advance the day indicator to the left hand position (Sunday). You will see a display as in figure 9.
- (3) Press  to advance hours and  to advance minutes (10 minute increments) to the desired start time. You have now entered the Sunday A time.

Skipping a program

When advancing the minutes between 50 and 00, you will see a display as in figure 10. This means that the program will be skipped. However, the temperatures will still be available for OVERRIDE.

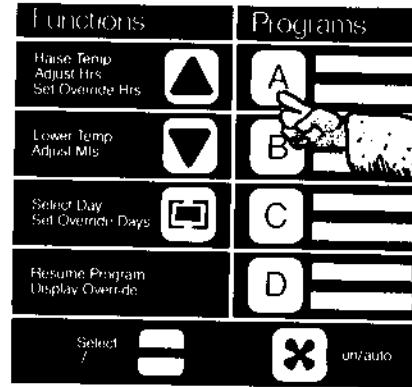

Figure 7. Heat set point



Figure 8. Cool set point

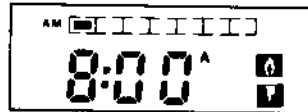
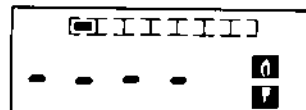
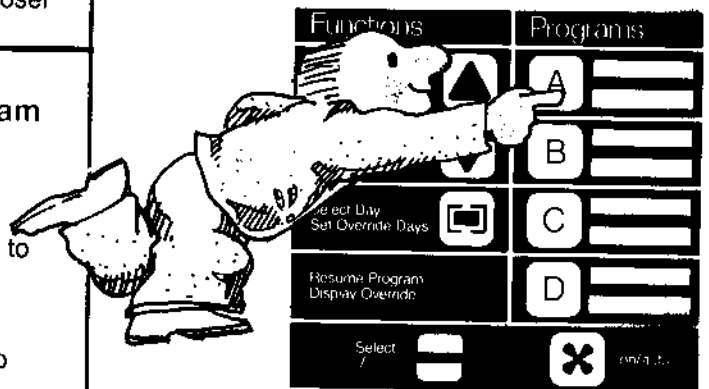

Figure 9. Time

Note: These displays are typical only. What you observe will differ if someone has already programmed the thermostat or if your system selection is not heat/cool (see step 4).



Push  to exit skip mode.

Figure 10. Program skipped

Functions	Programs
Raise Temp Adjust Hrs Set Override Hrs	A
Lower Temp Adjust Mts	B
Select Day Set Overri de Days	C
Resume Program Display Override	D
Select	on/auto

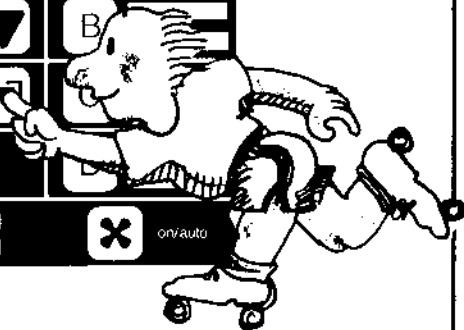

STEP 7. Enter the A times for the balance of the week

- (1) Press to advance the day indicator to Weekdays.
- (2) Press to advance hours and to advance minutes (10 minute increments) to the desired start time.
- (3) In a similar fashion program the time for Saturday by advancing the day indicator with and repeating substep (2).

Functions	Programs
Raise Temp Adjust Hrs Set Override Hrs	A
Lower Temp Adjust Mts	B
Select Day Set Overri de Days	C
Resume Program Display Override	D
Select	on/auto



STEP 8. Enter B, C, and D temperatures and times

Repeat steps 5 to 7 substituting , , or for .

Note: and times for Saturday and Sunday are in the factory set skip mode -----
To get out of skip mode, press when ----- is displayed. Now set the desired time.

Functions	Programs
Raise Temp Adjust Hrs Set Override Hrs	A
Lower Temp Adjust Mts	B
Select Day Set Overri de Days	C
Resume Program Display Override	D
Select	on/auto



STEP 9. Return to normal operation

Press and the display will alternate between temperature and time and control of your environment will be automatic as programmed.

STEP 10. Override

At any time you may override the scheduled program by merely pressing the program button **A** **B** **C** or **D** with the temperature you wish to hold. The display will then only show that temperature. The temperature will now control at the selected program temperature until you press **■** or the override time elapses.

Enter timed override

Note: An override time of 00.00 as in figure 11 will give a continuous override.

- (1) Press **■** until you observe your display as in figure 12.
- (2) Press and hold **▲** until the desired hours of override are shown in two right digits.
- (3) Press **☐** until the desired days of override are shown.

Figure 12 shows the factory setting of 3 hours of timed override and no days. Any time the override is used, (by simply pressing

button **A** **B** **C** or **D** which has the desired temperature) the temperature called for will control for 3 hours and then the normal program will resume again.

Functions	Programs
Raise Temp Adjust Hrs Set Override Hrs	A
Lower Temp Adjust Mts	B
Select Day Set Override Days	C
Resume Program Display Override	D
Select	=

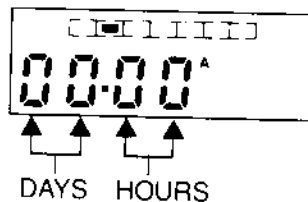

Figure 11.
Continuous override

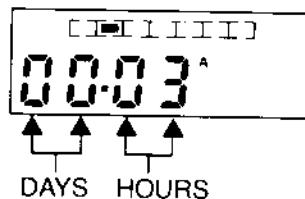
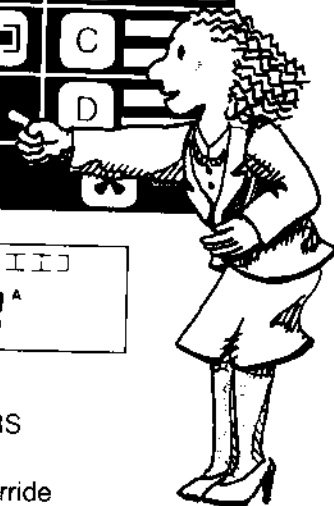

Figure 12.
Timed override



STEP 11. Verify Your Programs

- (1) Press **A** and check that it shows your desired heat temperature.
- (2) Press **A** again and check your cool setpoint.
- (3) Press **A** again and check your Saturday time.
- (4) Press **☐** **Note:** Ensure AM/PM is correct and check your Sunday time.
- (5) Press **☐** again and check your weekdays time.
- (6) In a similar manner, check your times and temperatures for B, C, and D.

Functions	Programs
Raise Temp Adjust Hrs Set Override Hrs	A
Lower Temp Adjust Mts	B
Select Day Set Override Days	C
Resume Program Display Override	D
Select	=
	X on/auto

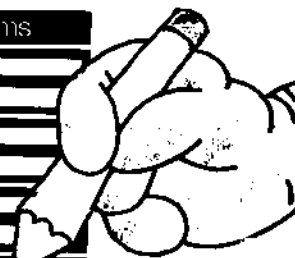

Write in your heat/cool temperatures in pencil.

Using some special features

Functions		Programs	
Raise Temp Adjust Hrs Set Override Hrs	▲	A	▬▬▬
Lower Temp Adjust Hrs	▼	B	▬▬▬
Select Day Set Override Days	☐	C	▬▬▬
Resume Program Display Override	▬	D	▬▬▬
Select	▬	☒ on/auto	



Fan operation

To select FAN ON press ☒. The fan will operate continuously and the fan symbol will be displayed. To select FAN AUTO, which operates the fan only when the system is running, press ☒ a second time and the fan symbol will disappear.

Battery symbol

The battery symbol indicates two conditions. If it is flashing, it indicates a missing or low battery condition. When this condition occurs, go to BATTERY INSTALLATION AND START-UP for instructions on how to replace the battery. If the battery symbol is displayed continuously, it indicates that the power is off and that the thermostat is maintaining its memory using the battery. A fresh battery will last 5 to 10 days without power to the thermostat. With continuous power the battery should last two to three years.

Caution: use alkaline battery only.

Keyboard disable

Keyboard buttons ▲ ▼ ☐ ▬

can be disabled by setting slide switch # 1 ON. This prevents the program from being altered by unauthorized people.

Installation instructions

- We recommend installer be a trained, experienced service technician.
- Disconnect power supply to systems before beginning installation to prevent personal injury or death from electrical shock or entanglement in moving parts and to prevent equipment damage.
- Ensure control voltage is 20-30 Vac.

Thermostat location

To ensure proper operation, the thermostat should be mounted on an inside wall in a frequently occupied area of the building. In addition, its position must be at least 18 inches from any outside wall, and approximately five feet above the floor in a location with freely circulating air of an average temperature. Be sure to avoid the locations described below when determining a site for the thermostat.

CAUTION: ZONE INTEGRITY MUST BE MAINTAINED TO EFFICIENTLY CONTROL UNITS OR GROUPS OF UNITS. UNLESS ZONES OF CONTROL ARE CONSIDERED AND ACCOUNTED FOR, ADJACENT UNITS MAY OPERATE IN HEATING AND COOLING MODES SIMULTANEOUSLY.

Do not locate the thermostat

- behind doors or in corners where freely circulating air is unavailable.
- where direct sunlight or radiant heat from appliances might affect control operation.
- on an outside wall.
- adjacent to, or in line with, conditioned air discharge grilles, stairwells, or outside doors.
- where its operation may be affected by steam or water pipes or warm air stacks in an adjacent partition space, or by an unheated/uncooled area behind the thermostat.
- where its operation will be affected by the supply air of an adjacent unit.
- near sources of electrical interference such as arcing relay contacts.

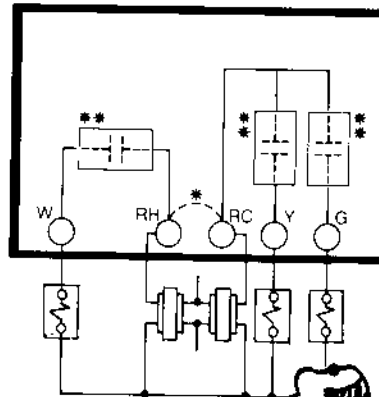

Connecting thermostat

Figure 14.
Typical connections for 1-stage
heat, 1-stage cool system

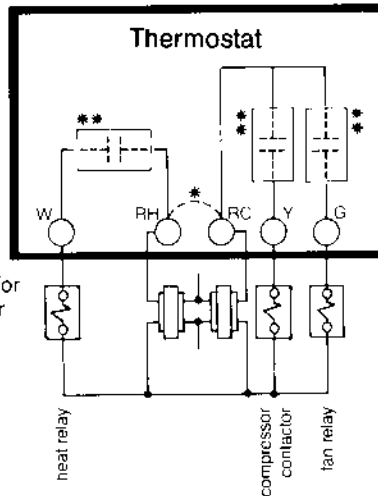

* jumper RC & RH for
single transformer
systems
** solid state switch
(not accessible)

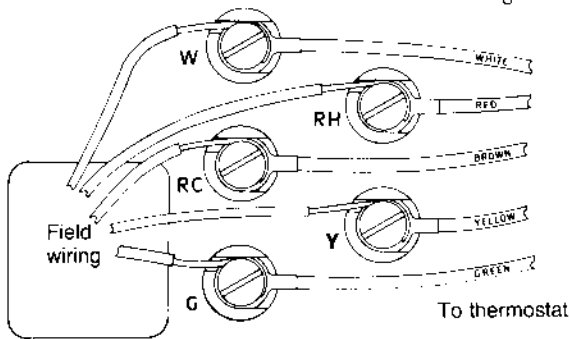

Figure 15a. Five wire two transformer system

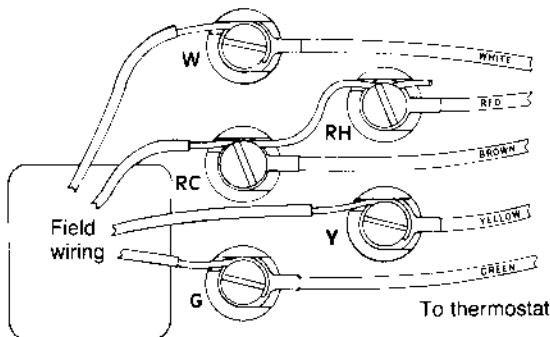

Figure 15b. Four wire single transformer system.
Note: jumper RC & RH.

Note:
For a 2 wire heat only system use W and RH.
For a 2 wire cool only system use Y and RC.

1. Make sure the power to the systems is off.

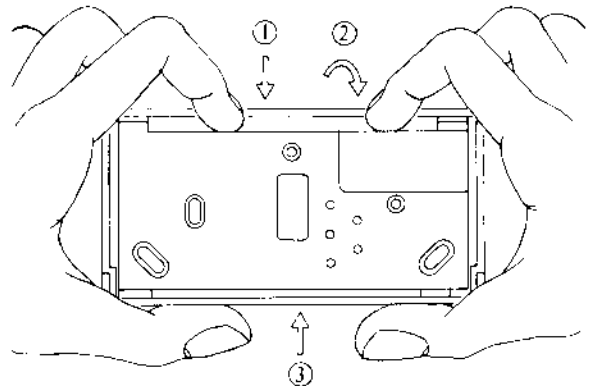

Figure 13. Removal of Mounting Plate
(thermostat lying face down on flat surface)

2. Pull front unit off of mounting plate.
3. For new installation, identify wires as per table 1. For replacement, identify wires before removing old thermostat.
4. Position the mounting plate so that all the control wires protrude through the centrally located slot (figure 15) Level for the appearance and mark the three mounting holes or use the template for locating the holes (back cover). Drill holes using a 3/16" (5mm) drill bit. Install supplied anchors, reposition the mounting plate and secure it to the wall. Do not overtighten screws.
5. Connect the field wires to the proper terminals (figure 14), by backing out each terminal screw and wrapping the respective wire around it.

Table 1

SYMBOL	OUTPUT TERMINAL DESCRIPTION
G	Energized when fan switch is on or when Y or W is energized. See fan option.
Y	Energized when cooling is required.
RC	24 Vac connection for cooling and fan transformer (Jumpered to RH for single transformer systems).
RH	24 Vac connection from equipment transformer.
W	Energized when heating is required.

Setting slide switches

6. There are a number of options that you can select with the slide switches. They slide up and down very easily using a pen. The ON position is marked on the block that encloses the switches (figure 16). Set the slide switches using the information in figure 16 as your guide.

Note: Slide switches 2, 3 and 4 can only be changed when the Ac power is off. If they are changed with the power on, your new option selections will not be recognized by the thermostat. Switch 1 may be changed at any time.

Figure 16. Slide switch settings

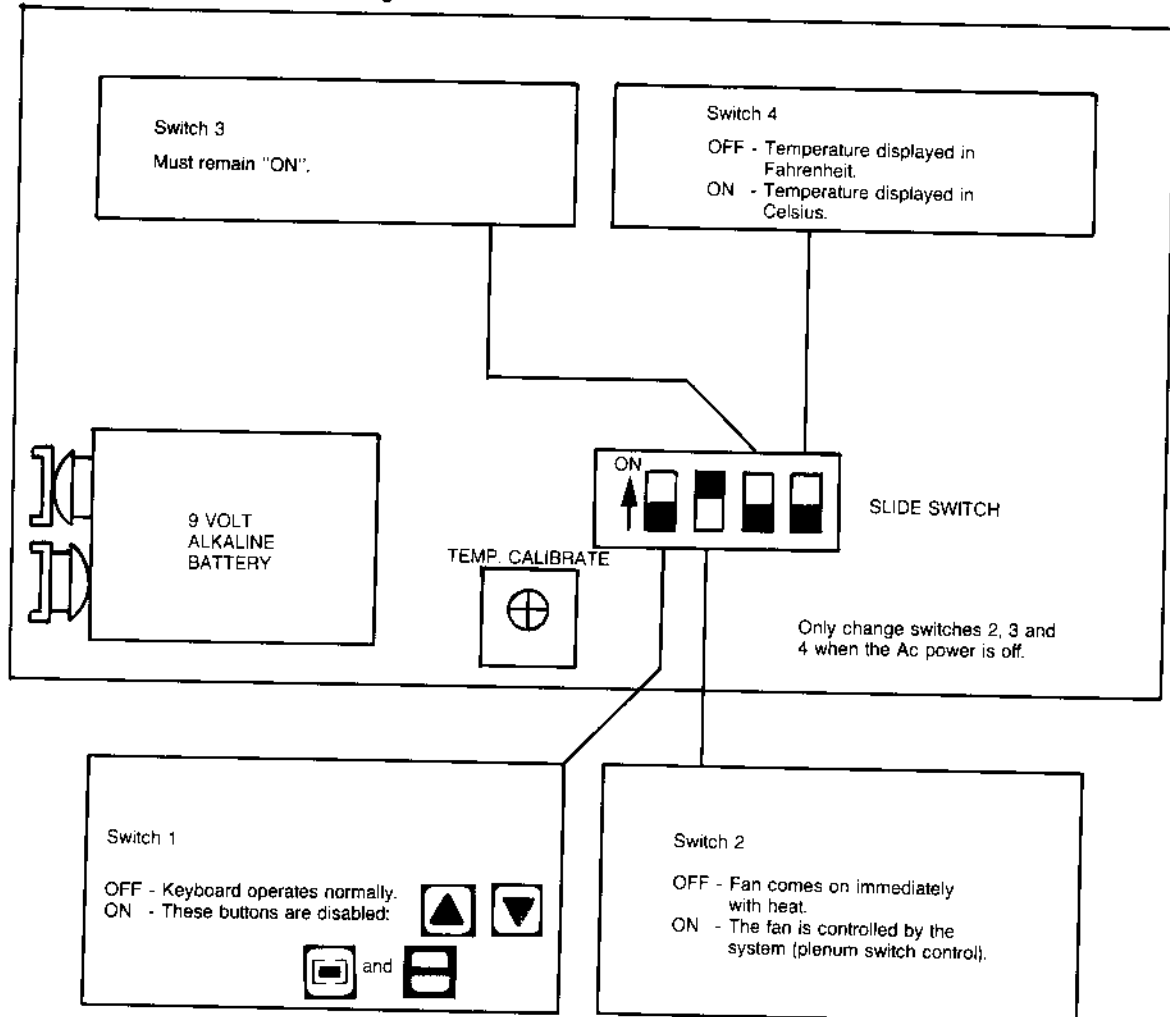

Battery installation & start-up

Figure 18. Start-up display



Figure 19. Rear view of front unit

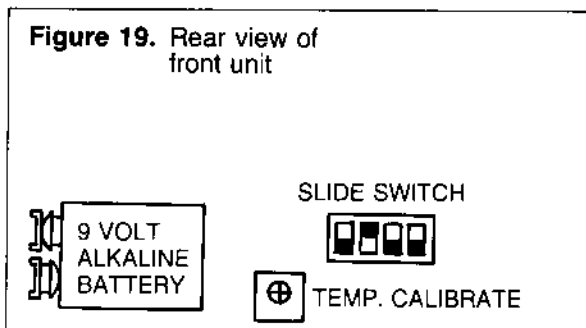

7. Install the battery.
 8. Allow a few seconds for the display to start flashing once per second (figure 18).
 9. Push . The display will alternate every four seconds between room temperature and time.
 10. Replace the thermostat front unit on mounting plate.
- Note:** Route the five control wires away from the battery area.

Table 2

STEP	PUSH BUTTON	DISPLAY SHOWS	RESPONSE
1			Heat mode
2		 	Auto heat/cool mode
3		(no symbol)	All systems go off after 7 seconds.
4			Cool mode
5		select required mode (step 1, 2 or 4) for further testing	
6		Stationary 68 or 73 (20 or 22.5)	Heating and cooling set-points. Room temperature will be maintained at these set-points
7	 	Increase or decrease of set point temperature	Equipment will respond subject to time delays
8	 hold	Time delays can be reduced to a few seconds by pressing and holding any one of the program buttons A, B, C, or D. Release when the stage indicator is displayed. Care must be taken not to short cycle the compressor. Set-point should be 10° higher than ambient in heating or 10° cooler than ambient in cooling. Note: return temperature to the original setting.	
9			Fan runs continuously
10		(no FAN symbol)	Fan operates automatically

Checking installation

CAUTION: UNIT HAS BUILT-IN TIME DELAYS FOR HEAT AND COOL. THEY MAY VARY DEPENDING ON ROOMTEMP RISE OR FALL. DELAYS CAN BE FROM 3 TO 15 MIN. PER STAGE.

Follow the checkout procedure outlined in Table 2. When the system power is turned on the battery symbol should disappear or flash if the battery is weak or missing. Minimum on and off times have been built into the thermostat to prevent HVAC equipment damage due to short cycling. These delays may be longer than specified if the HVAC equipment has built in delays.

Temperature Calibration

The temperature calibration control shown in figure 19 may be used for minor adjustments.

Trouble shooting guide

SYMPTOM	CAUSE	ACTION
UNIT APPEARS TO BE OKAY BUT WILL NOT ACTIVATE RELAYS OR RELAYS CHATTER	1) SOLID STATE SWITCH FAILURE 2) HIGH RESISTANCE AT EQUIPMENT	— REPLACE UNIT — INSTALL RELAY
HEAT OR COOL STATUS INDICATORS WILL NOT APPEAR	1) BUILT IN TIME DELAYS 2) NO 24 VAC	— OVERRIDE USING TIME DELAY SPEED UP — TURN ON 24 VAC
SYSTEM CYCLES BEFORE REACHING SET POINT	BUILT IN COMPUTER RECOVERY	— UNIT OPERATING NORMALLY
DISPLAY FLASHING-PROGRAM LOST	STATIC OR ELECTRICAL STORM	— REPROGRAM THERMOSTAT
TEMPERATURE READING INCORRECT	1) OUT OF CALIBRATION 2) EXTERNAL HEAT SOURCE 3) DOWN DRAFT AT THERMOSTAT	— RECALIBRATE WITH ACCURATE THERMOMETER. — ISOLATE STAT FROM HEAT SOURCE OR OVERHEAD DIFFUSERS.
BLANK DISPLAY	BATTERY DEAD	— TEST AND REPLACE BATTERY
STAT WILL NOT RETURN FROM SET BACK	1) OVERRIDE SET FOR DAYS 2) WRONG DAY OF WEEK	— PRESS RESUME, REMOVE DAYS FROM MEMORY. — PRESS DAY KEY & ADVANCE TO CORRECT DAY.

Battery removal

1. When replacing battery, maintain power to system to avoid losing your program.
2. Remove front unit as illustrated in figure 20.
3. Grasp the bottom of the battery and pull it away from the thermostat board. DO NOT pull the battery towards the components on the thermostat board as the battery may hit and damage them.

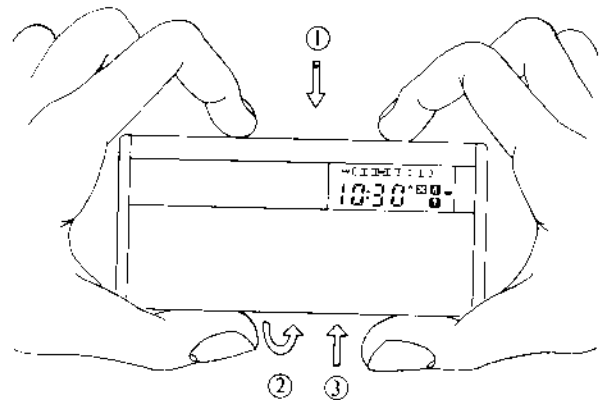

Figure 20. Removal of front unit for replacing battery or servicing after installation.

Specifications

Rated voltage	18-30 Vac
Rated current	0.050 — 1.5 Amp continuous for each output with surges to 4 Amps. Maximum 3 Amp continuous total of all outputs
Cycle rate	3 CPH
Minimum on/off times to prevent short cycling	6 minutes
Maximum recovery rate	6° F (3° C)/hr
Control range	
Heating	42 to 114° F in 1° steps or 7 to 43° C in 0.5° steps
Cooling	44 to 116° F in 1° steps or 8 to 44° C in 0.5° steps
Temperature measurement range	38 to 119° F or 5 to 45.5° C
Accuracy	± 1° F at 68° F or ± 0.5° C at 20° C
Battery	9 volt ALKALINE (Eveready #522 or equivalent) for memory retention during power outage
Quartz clock accuracy	± 80 seconds/month
Range of ambient operation	32 to 131° F (0 to 55° C)
Storage temperature	-30 to 131° F (-34 to 55° C)
Operating humidity range	5 to 90% RH non-condensing

Specifications subject to change without notice

Warranty

Full one year warranty. Valera Electronics Inc. warrants to the original purchaser that its ENERSTAT™ and components parts will be free from defects in workmanship and materials for a period of one year from the date of purchase. Your dealer will provide free replacement of your ENERSTAT upon proof of purchase.

Exclusions

This warranty does not apply in the event of misuse, abuse or as a result of unauthorized alterations or repairs. Valera Electronics Inc. will not be liable for any consequential damages including, without limitation, damages resulting from defects, loss of use, or misuse.

Valera Electronics Inc. manufactures similar products for Original Equipment Manufacturers. Such products may not be interchangeable with similar Valera products, and should be changed with products of such O.E.M.

This equipment, if installed in strict accordance with the manufacturers instructions, complies with the limits for a Class B computing device pursuant to Subpart J of Part 15 of FCC rules.

enerstat™

Developed and manufactured by
Valera Electronics Inc.,
5370 Canotek Road,
Ottawa, Canada K1J 8X7

Valera Corporation
Suite 103
Bridge and Port Authority Building
Ogdensburg, New York 13669

Valera Corporation Australia Pty. Ltd.
Southeast Asia
37 Benwerrin Drive, Burwood East 3151
Victoria, Australia

Valera Europe B.V.
Europe, Verlaat 9
2435 XE Zevenhoven
Netherlands