



## *Helpful hints*

Please take the few minutes required to read the programming instructions. Experience has shown that users who do read the instructions have no difficulty in programming and using their thermostat. Then find a convenient place to hang your Instruction Manual so that you can easily refresh your memory at a later date.

## *Introduction*

Your new thermostat contains a microcomputer that will automatically adjust the temperature of your home or office, up to four times each day, to suit your needs and at the same time save money and energy. It provides comfortable heating or cooling when you need it, and reduces energy expenditure while you are sleeping, or are out of the building, or on vacation. Your thermostat has separate weekend programming - we call it 5-1-1 so that 5 weekdays are the same, and then 2 successive days can each be different.

You can **OVERRIDE** or **SUPERCEDE** these settings whenever you wish to vary the schedule. If you have guests during the evening and you do not want the temperature to drop while they are visiting, the touch of a finger to your evening setting (for example 70° F or 21° C) will **OVERRIDE** your program and keep the temperature at its current setting until after your guests have gone. In addition, you can keep the temperature at a constant setting for any period from one hour up to 31 days using the **TIMED OVERRIDE** feature, explained on page 9.

We also recommend that everyone in the family read the instructions and, before installation, (by inserting the battery and following the steps that follow) put in a program of their choice. You will soon know how truly simple it is to know your thermostat.

The thermostat should then be installed. We recommend that a qualified technician install the thermostat because it is very important that it is properly located and all heating and cooling circuits are wired correctly. For **INSTALLATION INSTRUCTIONS** start on page 11.



## Display

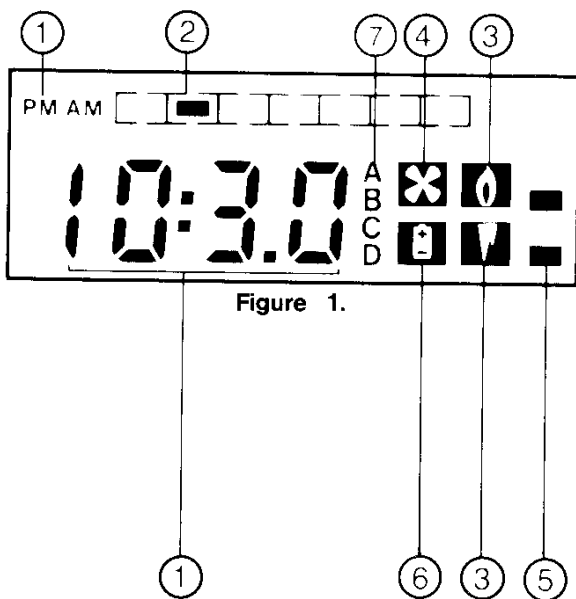

Figure 1.

- ① The time of day AM or PM and the actual room temperature are displayed alternating at 4 second intervals in normal operation, and the decimal or colon are constantly blinking when temperature and time respectively are shown.
- ① A set temperature and the time are displayed when programming. Nothing is blinking. The factory setting for all programs is 70°F or 20°C in heating, 74°F or 22°C in cooling and 6:00 AM.
- ① The duration of timed override is displayed. Nothing blinks. (see timed override page 9).  
Note: decimal point is displayed and not a colon as in a time display.
- ② Day of week, shows the 'day indicator' at beginning of 5 day program, typically Monday of the 5 days of the week.
- ③ Mode symbols, indicating system in heating (flame) heating and cooling (flame and icicle) cooling (icicle) or off mode (no symbols).
- ④ Fan symbol shows when the fan is in the 'on' continuous mode.
- ⑤ Indicators showing when heating (top bar) or cooling (bottom bar) is operating.
- ⑥ Indicates when unit is operating on the battery (thermostat is not installed or the power is off). When battery needs to be replaced, the symbol is flashing.
- ⑦ Indicates the program A,B,C, or D in which the thermostat is operating.

## Slide switches

The slide switches 1 to 10 are accessed from the rear of the front unit of the thermostat. They have been preset at the factory for the most frequently used settings and

However, if you wish to review the options, see page 13, and note that, if you desire a change, most switches must be preset before the battery is installed.

Figure 2. Rear view of front unit

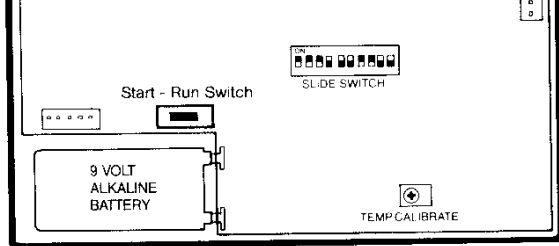

## Control buttons

There are Function buttons on the left and Program buttons on the right. Each button has multiple uses.

- Raises temperature, adjusts hours, sets override hours
- Lowers temperature, adjusts minutes
- Push to advance the day indicator to the correct day of week, sets override days when override is displayed
- Pressing once will resume program  
Pressing a second time will display timed override
- A** The program buttons A, B, C and D are used to gain access to programs in order to;
  - enter a program
  - override a program
  - change or check a program
- B**
- C**
- D**

Functions	Programs
Raise Temp. Adjust Hrs. Set Override Hrs.	A
Lower Temp. Adjust Mts.	B
Select Day Set Override Days	C
Resume Program Display Override	D
Select	on/auto

Front view

## Selecting your heat/cool system

By consecutively pressing and releasing the button the following symbols will appear:

COOL      AUTO      HEAT

With no heat or cool symbols displayed, the system is off.

With the fan button , you set the fan to continuous operation (ON mode) and the fan symbol is displayed. In the 'auto' mode, no fan symbol will be displayed and the fan operates or cycles as the system demands.

Functions	Programs
Raise Temp. Adjust Hrs. Set Override Hrs.	A
Lower Temp. Adjust Mts.	B
Select Day Set Override Days	C
Resume Program Display Override	D
Select	on/auto



## Typical residential schedule

Figure 3.

DAYS	PROGR.	HEAT°	COOL°	START TIME	AM/PM
Weekdays [ ] [ ] [ ] [ ] [ ] or any 5 consecutive days:	A	70	74	6.00	AM
	B	60	80	8.30	AM
	C	70	74	4.30	PM
	D	60	80	11.00	PM
Saturday [ ] [ ] [ ] [ ] [ ] [ ] or day following 5 consecutive days:	A	71	75	7.00	AM
	B	70	74	7.00	AM
	C	70	74	11.00	AM
	D	60	80	7.00	AM
Sunday [ ] [ ] [ ] [ ] [ ] [ ] [ ] or day preceding 5 consecutive days:	A	71	75	7.00	AM
	B	70	74	7.00	AM
	C	70	74	7.00	AM
	D	60	80	11.00	PM

## Typical office schedule

DAYS	PROGR.	HEAT°	COOL°	START TIME	AM/PM
Weekdays [ ] [ ] [ ] [ ] [ ] or any 5 consecutive days:	A	70	74	7.00	AM
	B	72	76	7.00	AM
	C	68	72	7.00	AM
	D	60	80	8.00	PM
Saturday [ ] [ ] [ ] [ ] [ ] [ ] or day following 5 consecutive days:	A	70	74	7.00	AM
	B	72	76	7.00	AM
	C	68	72	7.00	AM
	D	60	80	7.20	AM
Sunday [ ] [ ] [ ] [ ] [ ] [ ] [ ] or day preceding 5 consecutive days:	A	70	74	7.00	AM
	B	72	76	7.00	AM
	C	68	72	7.00	AM
	D	60	80	7.20	AM

**NOTE:**  
Put different temperatures in unused programs to provide greater selection, when using timed override.

The first thing to do before programming your thermostat is to determine your own personal comfort levels for each day as to temperature and time. Figure 3 is a typical schedule.

After the temperature has been lowered all night, it would be typical to have the thermostat begin to warm the house at 6:00 AM, if you get up at 7 AM. At 8:30 AM before everyone has left for the day, the thermostat can be set to lower the temperature to save you energy during the day. Before anyone arrives home in the afternoon, the temperature may again be increased to provide comfort for you when you return. Finally, at bedtime, the thermostat again lowers the temperature to save you energy all night.

Figure 4 is a blank form for you. Start with week-days, and write in your personal comfort level, and the time you want the furnace (or air conditioner) to come on in the morning to bring your home to that temperature. It is suggested that you set your desired program times about 1 hour before the time you actually require your home to reach the set temperature. So if you get up at 7 AM, set the furnace to come on at 6 AM.

Then write in the Saturday and Sunday settings.

*Fill in this chart  
to help program  
your schedule*

DAYS	PROGR.	HEAT°	COOL°	START TIME	AM/PM
Weekdays [ ] [ ] [ ] [ ] [ ] or any 5 consecutive days:	A				
	B				
	C				
	D				
Saturday [ ] [ ] [ ] [ ] [ ] [ ] or day following 5 consecutive days:	A				
	B				
	C				
	D				
Sunday [ ] [ ] [ ] [ ] [ ] [ ] [ ] or day preceding 5 consecutive days:	A				
	B				
	C				
	D				

Figure 4.

## Battery installation and startup

1. Separate the thermostat front unit from the mounting plate (page 12 figure 13).
2. Install the battery.
3. Operate the START-RUN switch back and forth and leave in RUN position.
4. Ensure that the display is flashing once per second as in figure 5. (If it is not, repeat step 3).

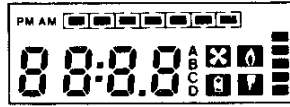

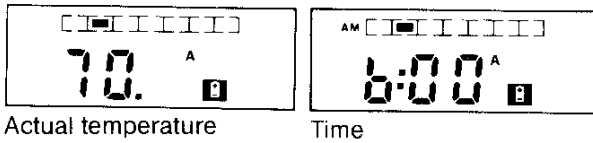

Figure 5. Display on start-up

Press the  button and observe the time and temperature alternating every 4 seconds.



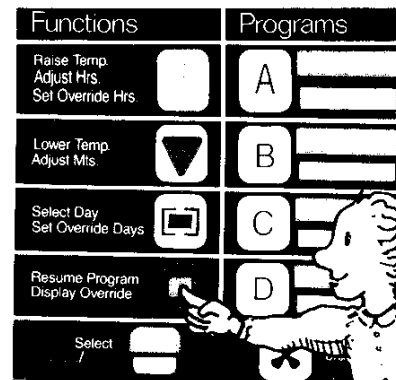

Actual temperature

Time



### Set correct time of day

When the display is showing time, press and hold the  button, until the hour digits advance to the correct hour, ensuring that AM/PM indicator is correct. (This button will not affect minutes).

Again when the time is displayed, press and hold  button until the minute digits advance to the correct minute. (This button will not affect the hours).

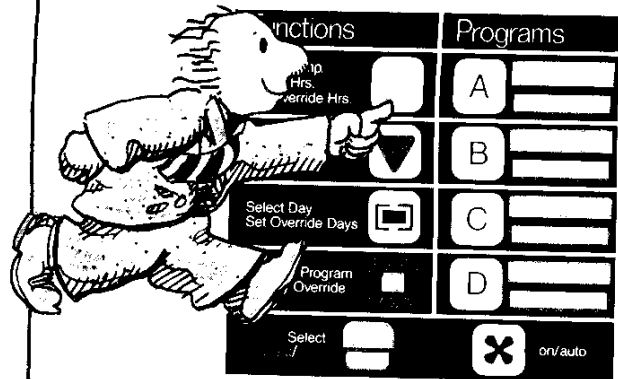

Functions	Programs
Raise Temp Adjust Hrs Set Override Hrs	A
Lower Temp Adjust Mts	B
Select Day Set Override Days	C
Resume Program Display Override	D
Select	on/off

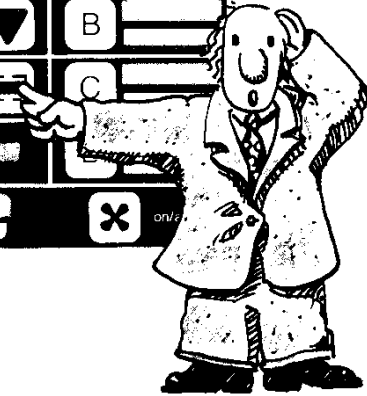

### Set correct day of week

Press the  button, and advance the day indicator to the correct day of the week. Figure 6 shows the indicator at Monday.





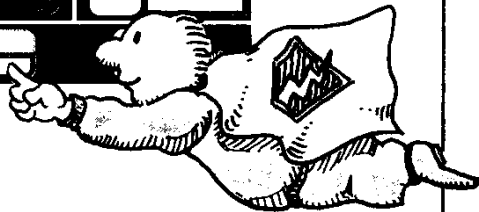

Figure 6.

Functions	Programs
Raise Temp Adjust Hrs Set Override Hrs	A
Lower Temp Adjust Mts	B
Select Day Set Override Days	C
Resume Program Display Override	D
Select	on/off







### Select heat/ cool system

By consecutively pressing and releasing the  button the following symbols will appear in this order on your display.

COOL	AUTO	HEAT
		
		

Select and display your system requirements ie, heat only, cool only, or heating and cooling (auto change over).

#### NOTE

- The battery symbol will show when power is off.
- Battery symbol will flash to indicate weak battery.
- When no heat or cool symbol is displayed, the system is off.
- If you have  only or  only displayed, you will program one temperature and the time. If you have both  and  (auto change over) you will program first heat, then cool, and then time.

## Enter your program for 5 weekdays

(1) Press and release **A**.

If your system selection includes heat you will observe the display as in (Figure 7).

(2) Press  to raise or  to lower, to your desired temperature

- Setting below 51°F or 10.5°C shuts system off.
- Setting below 55°F or 12°C may freeze pipes.

(3) Press and release **A** again. If your system selection includes cool only you'll observe the display as in figure 8. If system selection is heat or cool only you'll observe the display as in figure 9.

If display now shows time, press **A** again to display temperature set point before continuing.

Press  to raise or  to lower, to your desired temperature.

NOTE: The thermostat's design will not allow the heat and cool setpoints to be set closer than 4°F or 2°C.

(4) Press and release **A** again, and you will observe the display as Figure 9. Press  to advance the hours, and  to advance the minutes (10 minute increments) to the desired start time.

**You have now entered the "A" program for 5 days into the computer memory. Repeat above steps substituting **B**, **C** or **D** for **A**.**

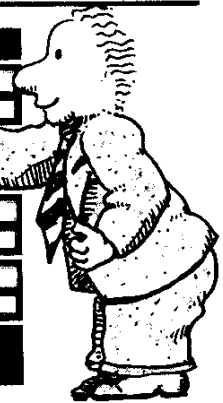
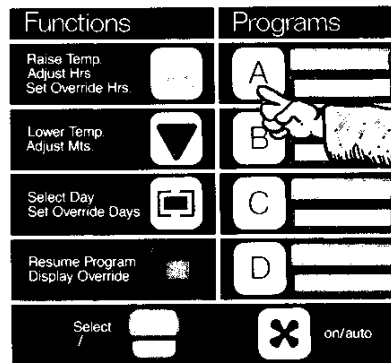

Figure 7. Heat set point

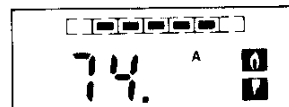
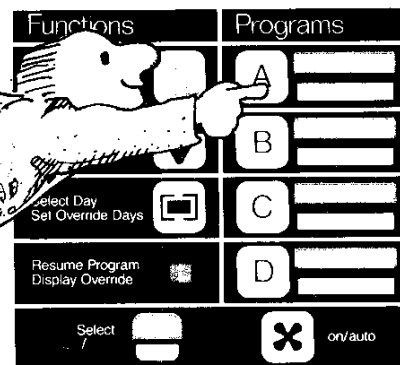

Figure 8. Cool set point

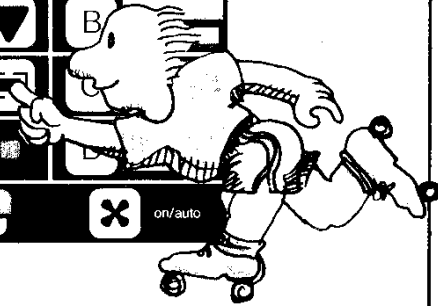

Figure 9. Time





Functions	Programs
Raise Temp. Adjust Hrs Set Override Hrs	A
Lower Temp. Adjust Mts	B
Select Day Set Override Days	C
Resume Program Display Override	D
Select	on/auto



### Enter program for Saturday

Press  and advance the day indicator to the right hand position. Now follow step 5 for programs A,B,C and D for Saturday.



Functions	Programs
Raise Temp. Adjust Hrs Set Override Hrs	A
Lower Temp. Adjust Mts	B
Select Day Set Override Days	C
Resume Program Display Override	D
Select	on/auto



### Enter program for Sunday

Press  again and advance the day indicator to the left hand position. Now follow step 5, for programs A,B,C, and D for Sunday.



Functions	Programs
Raise Temp. Adjust Hrs Set Override Hrs	A
Lower Temp. Adjust Mts	B
Select Day Set Override Days	C
Resume Program Display Override	D
Select	on/auto

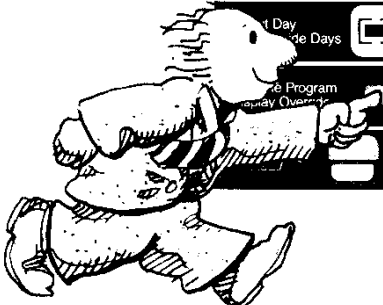

### Return to normal operations

Press  and the display will alternate between temperature and time and control of your environment will now be automatic as programmed.

### Continuous override

At any time you may override the scheduled program by merely pressing the program button **A**, **B**, **C** or **D** with the temperature you wish to hold. The display will then only show that temperature. The temperature will now control continuously at the selected program temperature until you press **□** (unless you have used the timed override feature, in which case the normal program will resume after the override time has elapsed).

### Enter timed override

While it is not necessary for normal operations, timed override is a very convenient feature and its use is strongly recommended. a minimum of 1 hour is mandatory if keyboard is to be disabled: see page 10.

(1) Press **□** until you observe your display as in figure 10.

(2) Press and hold **□** until the desired hours of override are shown in the two right digits as in figure 11.

(3) Press **□** until the desired days are shown.

Figure 11 shows a recommended typical setting of 3 hours of timed override and no days.

Any time the override is used, (by simply pressing button **A**, **B**, **C** or **D** which has the desired temperature) the temperature called for will control for 3 hours and then the normal program will resume again.

Functions	Programs
Raise Temp. Adjust Hrs. Set Override Hrs.	A
Lower Temp. Adjust Mts.	B
Select Day Set Override Days	C
Resume Program Display Override	D
Select on/off	

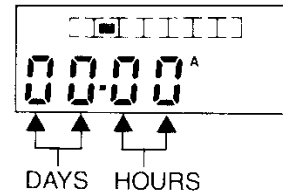

Figure 10.  
Display of timed override

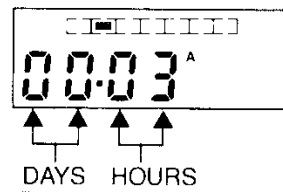
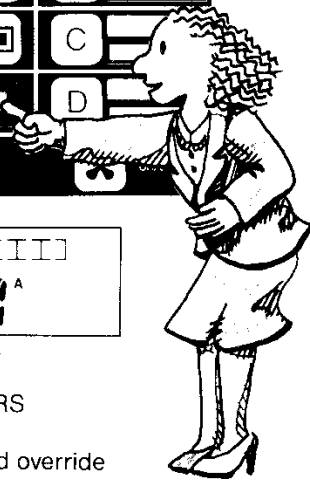

Figure 11.



### Verify your programs

1. Press **A** and check that it now shows your desired heat set point, for your 5 day program.

Press **A** again and check your cool set point.

Press **A** again and check your time.

(2) Repeat for programs B, C, and D.

(3) Repeat for Saturday and Sunday programs, after pressing **□** to advance to the desired day.

(4) Record your program in pencil on the thermostat (figure 12).

Simply pressing **□** returns to programmed operation.

Functions	Programs
Raise Temp. Adjust Hrs. Set Override Hrs.	A
Lower Temp. Adjust Mts.	B
Select Day Set Override Days	C
Resume Program Display Override	D
Select on/off	

Figure 12.

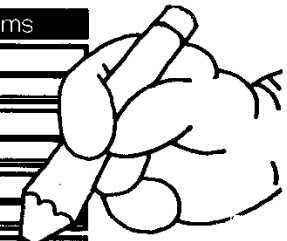

Functions	Programs
Raise Temp. Adjust Hrs. Set Override Hrs.	A
Lower Temp. Adjust Mts.	B
Select Day Set Override Days	C
Resume Program Display Override	D
Select * /	on/auto



## Fan operation

To select FAN ON press . The fan will operate continuously and the fan symbol will be displayed. To select FAN AUTO, which operates the fan only when the system is running, press a second time and the fan symbol will disappear.

## Battery symbol

The battery symbol indicates two conditions. If it is flashing, it indicates a missing or low battery condition. When this condition occurs, go to BATTERY INSTALLATION AND START-UP for instructions on how to replace the battery. If the battery symbol is displayed continuously, it indicates that the power is off and that the thermostat is maintaining its memory using the battery. A fresh battery will last 5 to 10 days without power to the thermostat. With continuous power the battery should last two to three years.

**Caution:** use alkaline battery only.

## Keyboard disable

All keyboard buttons (except and ) can be disabled by setting slide switch # 7 ON. This prevents the program from being altered by unauthorized people. **TIMED OVERRIDE MUST be used in conjunction with KEYBOARD DISABLE because RESUME is disabled.** We suggest a TIMED OVERRIDE interval of at least one hour.

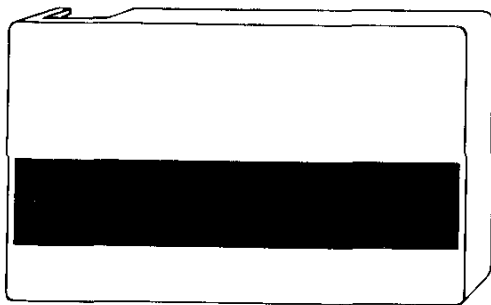

ACTUAL SIZE SHOWN

## Remote sensor Model RSK4

If you are planning on installing a remote sensor you must use a shielded cable with a ground wire or coaxial cable. Thermostat wire is not suitable for the remote sensor. Follow instructions that come with sensor.

- Disconnect power supply to systems before beginning installation to prevent personal injury or death from electrical shock or entanglement in moving parts and to prevent equipment damage.
- Ensure control voltage is 20-30 Vac.
- We recommend installer be a trained, experienced service technician.

## Thermostat location

To ensure proper operation, the thermostat should be mounted on an inside wall in a frequently occupied area of the building. In addition, its position must be at least 18 inches from any outside wall, and approximately five feet above the floor in a location with freely circulating air of an average temperature. Be sure to avoid the locations described below when determining a site for the thermostat.

**ZONE INTEGRITY MUST BE MAINTAINED TO EFFICIENTLY CONTROL UNITS OR GROUPS OF UNITS. UNLESS ZONES OF CONTROL ARE CONSIDERED AND ACCOUNTED FOR, ADJACENT UNITS MAY OPERATE IN HEATING AND COOLING MODES SIMULTANEOUSLY.**

Note: When optional remote sensor is used, these restrictions apply to the sensor location. The thermostat may then be located anywhere except in direct sunlight, harsh atmospheres or near sources of electrical interference.

## Do not locate the thermostat

- behind doors or in corners where freely circulating air is unavailable.
- where direct sunlight or radiant heat from appliances might affect control operation.
- on an outside wall.
- adjacent to, or in line with, conditioned air discharge grilles, stairwells, or outside doors.
- where its operation may be affected by steam or water pipes or warm air stacks in an adjacent partition space, or by an unheated/uncooled area behind the thermostat.
- where its operation will be affected by the supply air of an adjacent unit.
- near sources of electrical interference such as arcing relay contacts.

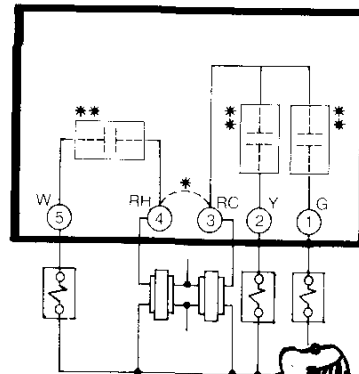

**Figure 14.**  
Typical connection for 1-stage heat, 1 stage cool (Thermostat terminal block)

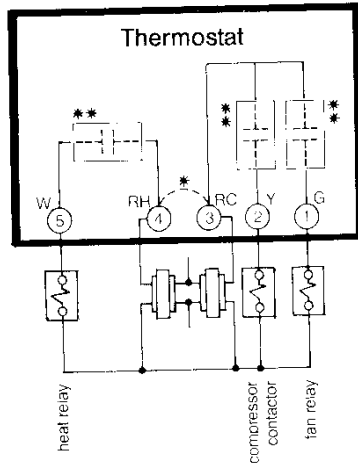

\* jumper 3 & 4 for single transformer systems  
\*\* solid state switch (not accessible)

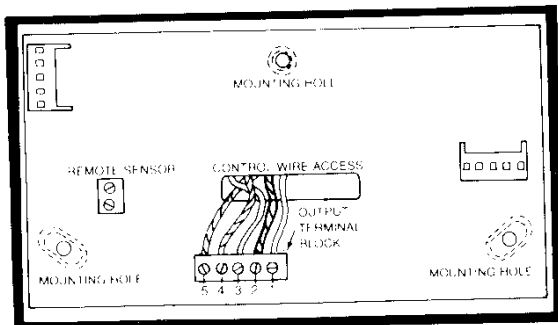

**Figure 15.** Mounting plate

1. Make sure the power to the systems is off.

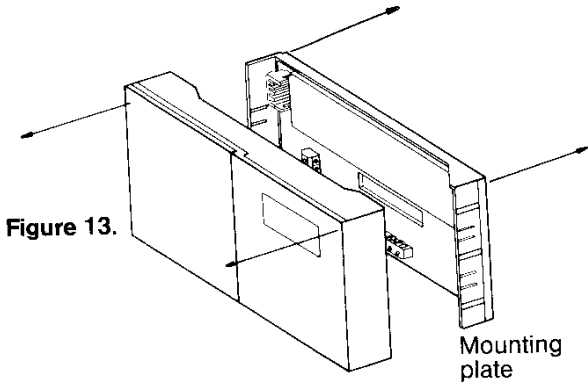

**Figure 13.**

2. Pull front unit off of mounting plate.
3. For new installation, identify wires as per table 1. For replacement, identify wires before removing old thermostat.
4. Position the mounting plate so that all the control wires protrude through the centrally located slot (figure 15 ) Level for appearance and mark the three mounting holes. Drill holes using a 3/16" (5mm) drill bit. Install supplied anchors, reposition the mounting plate and secure it to the wall. Do not overtighten screws.
5. Connect the control wires to the proper output terminals (figure 14).

**Table 1**

TERMINAL	SYMBOL	OUTPUT TERMINAL DESCRIPTION
1	G	Energized when fan switch is on or when Y or W is energized.
2	Y	Energized when cooling is required.
3	RC	24 Vac connection for cooling and fan transformer (Jumpered to RH for single transformer systems).
4	RH	24 Vac connection from equipment transformer.
5	W	Energized when heating is required.

**DO NOT INSTALL BATTERY UNTIL SLIDE SWITCHES INDICATED ARE SET!**

6. There are a number of options that you can select with the slide switches. They slide up and down very easily using a pen. The ON position is marked on the block that encloses the switches (figure 16). Set the slide switches using the information below as your guide.

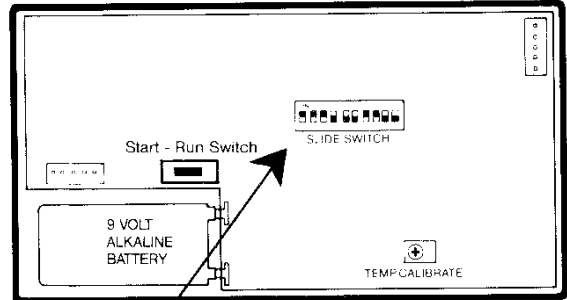

**Figure 16. Slide switches**

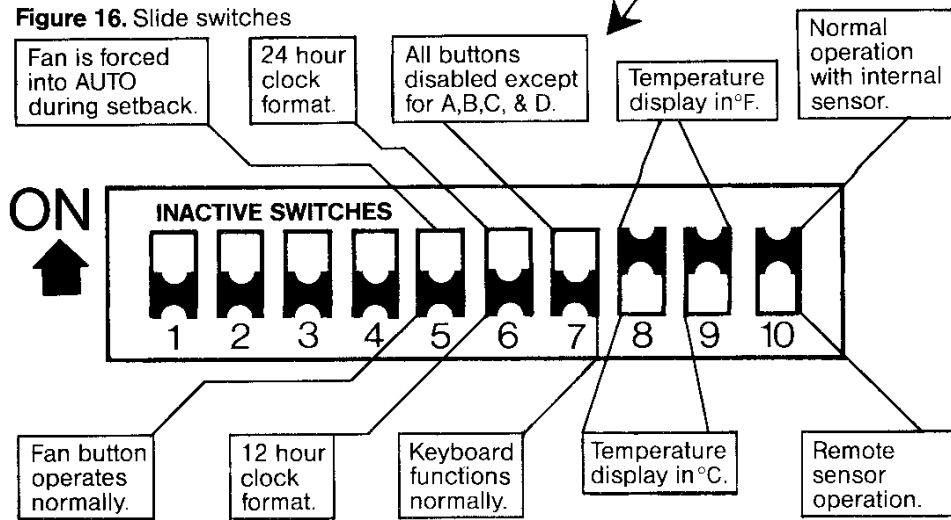

SWITCHES 1,2,3 and 4 are inactive

**SWITCH 5.**

OFF - Fan comes on only when heating or cooling equipment comes on (ON/AUTO). ON - In the FAN ON mode the fan runs continuously when the building is occupied but goes to FAN AUTO during setback or setup periods when the building is unoccupied. The setback temperature must be below 66°F or 18°C and the setup must be above 82°F or 26°C to use this feature.

**SWITCH 6.**

OFF - Time is displayed in 12 hour format.  
ON - Time is displayed in 24 hour (military or European) format.

**SWITCH 7.**

OFF - Keyboard operates normally.  
ON - All buttons are disabled except A, B, C, and D. This feature prevents a program from being accidentally (or deliberately!) altered. Ensure that you set a minimum of 1 hour (00.01) in timed override.

**SWITCHES 8 AND 9.**

OFF - Temperature displayed in Celsius.  
ON - Temperature displayed in Fahrenheit.

**SWITCH 10.**

ON - Normal operation with internal temperature sensor.  
OFF - For use with remote sensor. Do not place off until just before placing the front unit onto the mounting plate.

Figure 17. Start-up display



Figure 18. Battery installation

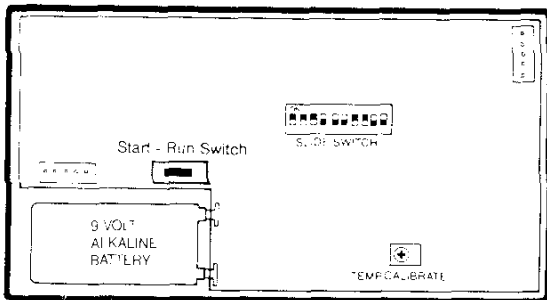

## Checking installation

**UNIT HAS BUILT-IN TIME DELAYS FOR HEAT AND COOL. THEY MAY VARY DEPENDING ON ROOMTEMP RISE OR FALL. DELAYS CAN BE FROM 3 TO 15 MIN. PER STAGE.**

Follow the checkout procedure outlined in Table 2. The thermostat should be in the OFF mode. When the system power is turned on the battery symbol should disappear or flash if the battery is weak or missing. Minimum on and off times have been built into the thermostat to prevent HVAC equipment damage due to short cycling. These delays may be longer than specified if the HVAC equipment has built in delays.

7. Install the battery.
8. Operate the START-RUN switch. Move to the START position. Wait, then move it to the RUN position and leave it there.
9. Ensure the display is flashing once per second (figure 17). If it is not, repeat step 8.
10. Push the RESUME button and the display will alternate every 4 seconds between room temperature and time.
11. Replace the thermostat front unit on mounting plate.

Table 2

STEP	PUSH BUTTON	DISPLAY SHOWS	RESPONSE
1			Cool mode
2			Auto heat/cool mode
3			Heat mode
4		(no symbol)	All systems go off after 7 seconds.
5		select required mode (step 1, 2, or 3) for further testing	
6		Stationary 70 or 74 (20.0 or 22.0)	Heating and cooling set-points. Room temperature will be maintained at these set-points
7	 	Increase or decrease of set point temperature	Equipment will respond subject to time delays
8	 hold		<p><b>REDUCING BUILT-IN TIME DELAY:</b></p> <ol style="list-style-type: none"> <li>1. The unit must be in "F" (Slide switches 8 and 9 on).</li> <li>2. Select either heat or cool to be tested.</li> <li>3. Raise or lower heat or cool setpoint 10° in  </li> <li>4. Press and hold the  until system energizes. (Page 2 no. 5)</li> <li>5. Equipment will now operate subject to its own delays</li> </ol>
9			Fan runs continuously subject to Figure 16, Page 13, switch # 5
10		(no FAN symbol)	Fan operates automatically

SYMPTOM	CAUSE	ACTION
UNIT APPEARS TO BE OKAY BUT WILL NOT ACTIVATE RELAYS OR RELAYS CHATTER	1) SOLID STATE SWITCH FAILURE 2) HIGH RESISTANCE AT EQUIPMENT 3) 2 TRANSFORMER SYSTEM OUT OF PHASE	- REPLACE UNIT - LOAD DOWN RELAY COIL WITH 4700 ohm 1 WATT RESISTOR OR INSTALL RELAY. - PHASE TRANSFORMERS
HEAT OR COOL STATUS INDICATORS WILL NOT APPEAR	1) BUILT IN TIME DELAYS	- OVERRIDE USING TIME DELAY SPEED UP.
DISPLAY LOCKED INTO A,B,C,D, PROGRAM RESUME NOT OPERATING	1) KEYBOARD DISABLED BY SLIDE SWITCH #7 2) SLIDE SWITCH #10 OFF & NO REMOTE SENSOR CONNECTED OR REMOTE SENSOR CIRCUIT OPEN	- PLACE #7 TO "OFF" & RESUME . PUT IN MINIMUM OF 00.01 (1 HR) INTO OVERRIDE TO PREVENT REPEAT - CHECK SWITCH AND REMOTE CIRCUIT
SYSTEM CYCLES BEFORE REACHING SET POINT	BUILT IN COMPUTER RECOVERY	UNIT OPERATING NORMALLY
DISPLAY FLASHING-PROGRAM LOST	1) STATIC ELECTRICITY 2) HIGH FREQUENCY INTERFERENCE	- DISCHARGE BEFORE TOUCHING STAT! - USE SHIELDED CABLE WITH REMOTE SENSOR.
TEMPERATURE READING INCORRECT	1) OUT OF CALIBRATION 2) EXTERNAL HEAT SOURCE 3) DOWN DRAFT AT THERMOSTAT	- RECALIBRATE WITH ACCURATE THERMOMETER. - ISOLATE STAT FROM HEAT SOURCE OR OVERHEAD DIFFUSERS.
BLANK DISPLAY	1) START-RUN SWITCH LEFT IN START POSITION 2) BATTERY DEAD 3) STATIC ELECTRICITY	- PLACE IN RUN POSITION - TEST AND REPLACE - RESET WITH START-RUN SWITCH
DISPLAY READING 24 HR FORMAT	SLIDE SWITCH #6 IN THE "ON" POSITION	SET IN "OFF" POSITION IF DESIRED
FAN COMES ON WITH HEAT USA ONLY	NORMAL AFTER DATE CODE 85-08	IF NOT DESIRED CUT RESISTOR FROM PC BOARD. MARKED WITH WHITE PAINT ON STAT BOARD.
ERRATIC TEMPERATURE READING	1) WHEN REMOTE SENSOR IS INSTALLED #10 SWITCH MUST BE IN "OFF" POSITION 2) FAULTY THERMISTOR 3) INCORRECT SHIELDING CONNECTIONS OR SHIELD GOES TO MECHANICAL GROUND.	- DISCONNECT REMOTE SENSOR LEADS IF INTERNAL THERMISTOR IS TO BE USED TEMPORARILY. REPLACE OR CHECK WITH ohm METER 10,000 ohm- approximate - CHECK REMOTE SENSOR WIRING.
CLOCK SPEEDS UP (REMOTE SENSOR)	HIGH VOLTAGE SPIKES REACHING THERMOSTAT	INSTALL 10 UF CAPACITOR ACROSS REMOTE SENSOR TERMINALS IN SUB-BASE. SEE REMOTE SENSOR INSTRUCTIONS
STAT WILL NOT RETURN FROM SET BACK	1) OVERRIDE SET FOR DAYS 2) WRONG DAY OF WEEK 3) KEYBOARD LOCKED	- PRESS RESUME, REMOVE DAYS FROM MEMORY. - PRESS DAY KEY & ADVANCE TO CORRECT DAY. - UNLOCK WITH SLIDE SWITCH #7



Rated voltage	20 – 30 Vac
Rated current	0.050 – 1.5 Amp continuous for each output with surges to 4 Amps
Cycle rate	3 CPH cooling 6 CPH heating
Minimum on/off times to prevent short cycling	6 minutes for cooling 3 minutes for heating
Maximum recovery rate	6°F (3°C)/hr cooling 12°F (6°C)/hr heating
Control range	
Heating	51 to 106°F in 1° steps or 10.5 to 38°C in 0.5° steps
Cooling	55 to 110°F in 1° steps or 12.5 to 40°C in 0.5° steps
Temperature measurement range	50 to 113°F or 10 to 41.5°C
Accuracy	±0.5°F ± 0.05°F/°F difference from 70°F
Battery	9 volt ALKALINE (Eveready # 522 or equivalent) for memory retention during power outage
Quartz clock accuracy	± 80 seconds/month
Range of ambient operation	32 to 131°F (0 to 55°C)
Storage temperature	– 30 to 131°F (– 34 to 55°C)
Operating humidity range	5 to 90% RH