

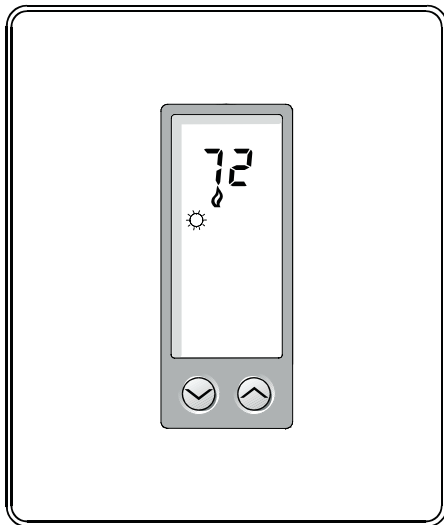

DSL-345

Single Setpoint Heating & Cooling
Auto Changeover with Reversing Valve
OPERATING INSTRUCTIONS



SEE REVERSE FOR INSTALLATION INSTRUCTIONS

11-265

Your new digital thermostat has been designed to provide accurate control and display of room temperature. In addition, it also will display all relevant information pertaining to your system.

The clearly marked buttons and informative display make it extremely easy to understand and simple to use.

Please take a few moments to read the brief instructions and familiarize yourself with the various functions in order to obtain maximum benefit from this truly unique electronic control.

GENERAL INFORMATION

The thermostat normally displays room temperature, mode of operation and whether cooling or heating is currently on. The two buttons on the front of the unit allow complete control of the equipment.

Raising or lowering the setpoint is as simple as pushing a button. In addition, you may choose to display the temperature in °F or °C.

The thermostat also allows you to select continuous fan operation (useful when using an air cleaner) or have the fan come on with the equipment.

The model DSL-345 is a single-setpoint heat/cool thermostat. It features a narrow, fixed deadband between internal heat and cool setpoints.

USER CONTROLS

COOLER

To lower the temperature in the zone, press and hold the ▼ button until the desired temperature is displayed, then release.

WARMER

To raise the temperature in the zone, press and hold the ▲ button until the desired temperature is displayed, then release.

The number that is displayed when the button is released is the new setpoint or control temperature for the zone. The display will return to the normal room temperature display after a few seconds.

CELSIUS/FAHRENHEIT

Simultaneously press ▼ and ▲ to switch between Celsius and Fahrenheit temperature display.

USER CONTROLS (Cont'd)

FAN

The fan will come on automatically when the system is operating, but there is no indication of this on the display. To select continuous fan operation, press the FAN button and the display will show . This is recommended for electronic air cleaners or continuous ventilation requirements.

NOTE: For fan coil applications in which the O and B output terminals control valve position, *DO NOT* use continuous fan.

REMOTE SENSOR (OPTION)

RS1 – RS2 – RS+V

The thermostat is designed to accept the electronic remote sensor, which will allow you to locate your thermostat in an area away from view. Indoor and outdoor sensors are available separately.

USER CONTROLS (Cont'd)

HEAT & COOL INDICATION ON DISPLAY

When the equipment is off, both flame and snowflake are on steadily. When the thermostat is calling for heat, the flame flickers and the snowflake goes off. When cooling, the snowflake flickers and the flame goes off.

LIMITED OVERRIDE

When the keyboard is locked (DIP switch #2 ON), the user may override the temperature setpoint for 1 hour by pressing either the ▼ or ▲ button. The range of temperature override is ±6°F or ±3°C from the programmed daytime setpoint.

POWER FAILURES

Your thermostat employs the latest developments in solid state electronic technology.

One of the unique features of your thermostat is that no battery is required to maintain your selected setpoints in the event of a power loss as the memory is unaffected by power failures of any duration.

When power is restored, the thermostat will continue operating as if the power had never been off.

TEMPERATURE ACCURACY

Full temperature accuracy will be realized only after the thermostat has been installed and powered for at least one hour.

NOTES

This page intentionally left blank.

One (1) Year Limited Warranty

The manufacturer warrants to the original purchaser that its product and component parts will be free from defects in workmanship and materials for a period of one (1) year from the date of purchase. Return to the original point of purchase for replacement of your product.

Warranty Limitations

This warranty begins at date of purchase.

Warranty is Void if:

The date code is defaced or removed.
The product has a defect or damage due to product alteration, connection to an improper electrical supply, shipping and handling, accident, fire, flood, lightning, or other conditions beyond the control of the manufacturer.
The product is not installed according to the manufacturer's instructions and specifications.
The product has been installed near sources of electromagnetic interference (EMI) such as arcing relay contact.

Owner's Responsibility

Provide proof of purchase.
Provide normal care and maintenance.
Pay for freight, labor and travel.
Pay for service calls related to product installation.
Return any defective product.
In no event shall the manufacturer be liable for incidental or consequential damages.
This warranty gives you specific legal rights and you may have others which vary by state and/or province. For example, some states and/or provinces do not allow the exclusion or limitation of incidental or consequential damages so this exclusion may not apply to you.
The manufacturer's continuing commitment to quality products may require a change in specifications without notice.

This equipment, if installed in strict accordance with the manufacturer's instructions, complies with the limits for a Class B computing device pursuant to Subpart J of Part 15 of FCC rules.

INSTALLATION INSTRUCTIONS

LOCATION

To ensure proper operation, the thermostat should be mounted on an inside wall in a frequently occupied area of the building. In addition, its position must be at least 18" (46cm) from any outside wall, and approximately 5' (1.5m) above the floor in a location with freely circulating air of an average temperature.

BE SURE TO AVOID THE FOLLOWING LOCATIONS:

- behind doors or in corners where freely circulating air is unavailable
- where direct sunlight or radiant heat from appliances might affect control operation
- on an outside wall
- adjacent to, or in line with, conditioned air discharge grilles, stairwells, or outside doors
- where its operation may be affected by steam or water pipes or warm air stacks in an adjacent partition space, or by an unheated/uncooled area behind the thermostat
- where its operation will be affected by the supply air of an adjacent unit
- near sources of electrical interference such as arcing relay contacts

THERMOSTAT INSTALLATION

1. Insert a flat blade screwdriver or coin 1/8" into the slot located in the bottom center of the thermostat case and twist 1/4 turn. When you feel or hear a click, grasp the case from the bottom two corners and separate from the subbase as shown in the diagram at the right. Some models require more force than others when separating due to the number of terminals on the subbase.
2. Swing the thermostat out from the bottom.
3. Lift the thermostat up and off the subbase.
4. Place the rectangular opening in the subbase over the equipment control wires protruding from the wall and, using the subbase as a template, mark the location of the two mounting holes (exact vertical mounting is necessary only for appearance).
5. Use the supplied anchors and screws for mounting on drywall or plaster; drill two 3/16" (5mm) diameter holes at the marked locations; use a hammer to tap the nylon anchors in flush to the wall surface and fasten subbase using the supplied screws. (Do not over-tighten!)
6. Connect the wires from your system to the thermostat terminals as shown in the wiring diagrams. Carefully dress the wires so that any excess is pushed back into the wall cavity or junction box. Ensure that the wires are flush to the plastic subbase. The access hole should be sealed or stuffed to prevent drafts from affecting the thermostat.

7. Before the thermostat is reinstalled on the subbase, install the optional indoor remote sensor (model 8002), if used. Refer to the installation instructions supplied with the model 8002.

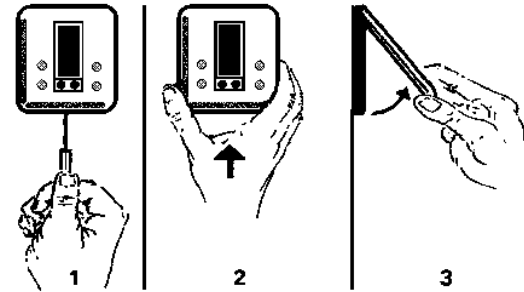

REPLACING THE THERMOSTAT ON THE SUBBASE

1. Position the thermostat on the hinged tabs located at the top of the subbase.
2. Gently swing the thermostat down and press on the bottom center edge until it snaps in place.

SLIDE SWITCH SETTINGS

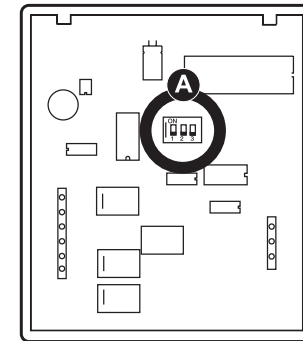

Thermostat Body, Rear View

DETAIL A

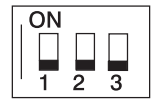

DIP Switch in the OFF position

1. 4 minute minimum ON
2. Keypad unlocked
3. Fan immediate with call for heat

DIP Switch in the ON position

1. 2 minute minimum ON
2. Keypad locked
3. Fan on with plenum switch

*NOTE: The BLACK rectangle denotes factory setting.

SPECIFICATIONS

Rated Voltage	20-30 VAC, 24 nominal
Rated A.C. Current	0.05 Amps to 0.75 Amps continuous per output with surges to 3 Amps Max.
Rated D.C. Current	0 Amps to 0.75 Amps continuous per output with surges to 3 Amps Max.
Control Range	Heating: 38° to 88°F in 1° Steps 5° to 30°C in 1° Steps Cooling: 60° to 108°F in 1° Steps 16° to 40°C in 1° Steps

Thermostat Measurement Range	28° to 124°F or 0° to 48°C
O.D.T. Displayed Range	-50° to 124°F or -48° to 48°C
Control Accuracy	± .5°C at 20°C ± 1°F at 68°F
Minimum Deadband	(between heating and cooling) 2°F or 1°C

NOTE: This thermostat contains electronic circuitry replacing the conventional mechanical anticipator.

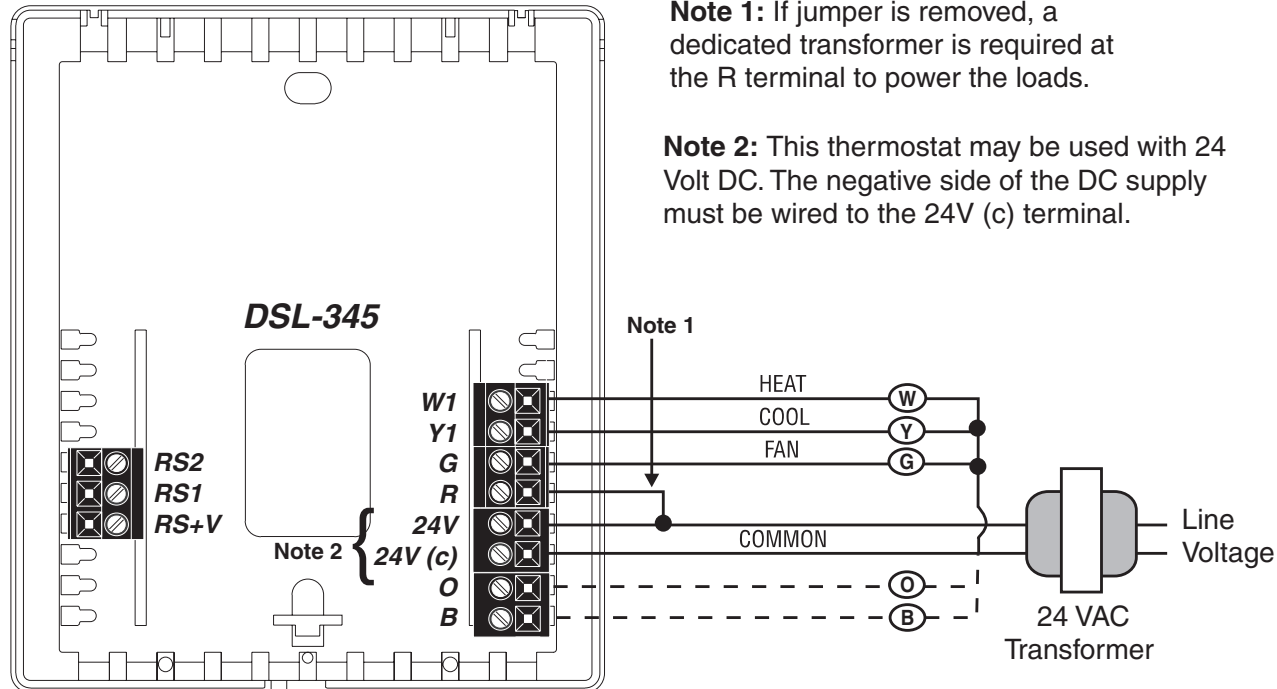

Note 1: If jumper is removed, a dedicated transformer is required at the R terminal to power the loads.

Note 2: This thermostat may be used with 24 Volt DC. The negative side of the DC supply must be wired to the 24V (c) terminal.

OUTPUT TERMINAL FUNCTIONS

- W1** Energizes on a call for first stage heat
- Y1** Energizes on a call for first stage cool
- G** Energizes with a call for heating or cooling or selected by the FAN button
- R** Independent switching voltage
- 24 V** 24 VAC
- 24 V(c)** 24 VAC (common)
- O** Energizes the reversing valve continuously in cooling mode
- B** Energizes the reversing valve continuously in heating and off modes
- RS2** For outdoor temperature sensor
- RS1** and/or indoor remote sensor options.
- RS+V** Refer to the instructions included with the sensors.