

DESCRIPTION OF ICONS

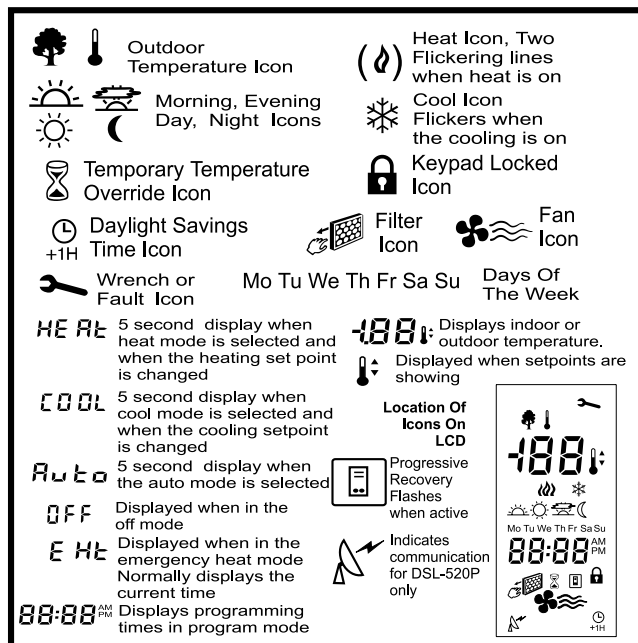

Display icons vary according to the model. Your thermostat may not display all of the icons shown.

Power Outages & Power Failures During Regular Program Schedule

Should your power fail at any time during the regular program, the thermostat will maintain the clock internally for up to 2 hours. If the power has not been restored during this time period, the clock will stop. When the power is restored, the thermostat clock defaults to a flashing 12:00 AM. **The thermostat will be held in the Night program until the user resets the clock.** The thermostat will display AC when the 24 VAC is not powered. One of the unique features of your thermostat is that there is no battery required to maintain your selected setpoints in the event of a power loss, since the memory is unaffected by power failures of any duration. There is no reason to reprogram the setpoint temperatures or start times since the thermostat will retain these program parameters.

DIP SWITCH OPTIONS AND FUNCTIONS

Positioning the DIP switches in either the ON or OFF position enables you to choose between two different options. The DIP switches are located on the interior of your thermostat and may be accessed by following the procedure for removing the thermostat from the subbase. The following list describes your DIP switch options.

DIP Switch No.	DIP Switch OFF	DIP Switch ON
1	4 minute minimum ON	2 minute minimum ON
2	Keypad unlock	Keypad lock
3	Normal	Add-on
4	Not used (must be OFF)	Not used
5	LED #1 + No icon	LED #1 + Filter icon
6	LED #2 + No icon	LED #2 + Fault icon

1. 2 Minute or 4 Minute On Times This option allows you to run the equipment for either a 2 or 4 minute minimum off and on time.

2. Keypad Lock In the ON position locks out all buttons except the OUTDOOR button.

3. Normal or Add-On The thermostat is equipped to enhance the performance of an add-on heat pump. In most applications it will perform the function of a fossil fuel kit. Select ADD-ON by placing the switch in the ON position. The thermostat will turn off the compressor with a call for auxiliary heat. With the switch set to Normal (OFF) the compressor and auxiliary heat may be on simultaneously.

4. Not Used Set to OFF.

5. LED and Filter Icon In the ON position the display will show the filter icon when the left LED is energized.

6. LED and Wrench Icon In the ON position the display will show the wrench icon when the right LED is energized.

SPECIFICATIONS

Rated Voltage	20-30 VAC, 24 nominal
Rated A.C. Current	0.050 Amps to 0.75 Amps continuous per output with surges to 3 Amps Max.
Rated D.C. Current	0 Amps to 0.75 Amps continuous per output with surges to 3 Amps Max.
Control Range	Heating: 38° to 88°F in 1° Steps 5° to 30°C in 1° Steps Cooling: 60° to 108°F in 1° Steps 16° to 40°C in 1° Steps

Thermostat Measurement Range	28° to 124°F or 0° to 48°C
O.D.T. Displayed Range	-50° to 119°F or -48° to 47°C
Control Accuracy	±0.5°C at 20°C, ±1°F at 68°F
Minimum Deadband	(between heating and cooling) 2°F or 1°C

Note: This thermostat contains electronic circuitry replacing the conventional mechanical anticipator.

ENERGY STAR COMPLIANT

Energy Star labeled products use less energy than other products, save you money on utility bills and help protect the environment. Energy Star setpoints are now standard on all thermostats to ensure maximum efficiency and comfort.

Non-Programmable

Heating 70°F (21°C)/Setback Heating 62°F (17°C)
Cooling 78°F (25°C)/Setback Cooling 82°F (27°C)

Programmable Heating

Morning 70°F (21°C) Day 62°F (17°C)
Evening 70°F (21°C) Night 62°F (17°C)

Programmable Cooling

Morning 78°F (25°C) Day 85°F (28°C)
Evening 78°F (25°C) Night 82°F (27°C)

One (1) Year Limited Warranty

The manufacturer warrants to the original purchaser that its product and component parts will be free from defects in workmanship and materials for a period of one (1) year from the date of purchase. Return to the original point of purchase for replacement of your product.

Warranty Limitations

This warranty begins at date of purchase.

Warranty is Void if:

The date code is defaced or removed.
The product has a defect or damage due to product alteration, connection to an improper electrical supply, shipping and handling, accident, fire, flood, lightning, or other conditions beyond the control of the manufacturer.

The product is not installed according to the manufacturer's instructions and specifications.

The product has been installed near sources of electromagnetic interference (EMI) such as arcing relay contacts.

Owner's Responsibility

Provide proof of purchase.
Provide normal care and maintenance.
Pay for freight, labor and travel.
Pay for service calls related to product installation.
Return any defective product.

In no event shall the manufacturer be liable for incidental or consequential damages.

This warranty gives you specific legal rights and you may have others which vary by state and/or province. For example, some states and/or provinces do not allow the exclusion or limitation of incidental or consequential damages, so this exclusion may not apply to you. The manufacturer's continuing commitment to quality products may require a change in specifications without notice.

This equipment, if installed in strict accordance with the manufacturer's instructions, complies with the limits for a Class B computing device pursuant to Subpart J of Part 15 of FCC rules.

Operating Instructions

5-2 Day Programmable Thermostat

Single Compressor Auto Changeover Heat Pump Thermostat 2 Heat/1 Cool

NEW & IMPROVED FEATURES

Your new electronic programmable thermostat has been made even better by the introduction of several new and improved features. Building on its reputation for efficient and dependable operation, your thermostat now offers the following list of enhancements.

Progressive Recovery (available on programmable models)

Selecting progressive recovery on your programmable thermostat causes the thermostat to anticipate the programmed setpoint change, thus allowing the climate-controlled area to reach the desired setpoint when required. The progressive recovery option is selected by pressing the FAN and PROGRAM buttons simultaneously.

Thermostat and Sensor Calibration

Release 3 provides easy calibration of the thermostat and remote sensors. Simply press and hold the FAN button for 10 seconds and adjust with the up or down buttons.

Programming Revert Time Extended

The programming revert time has been extended to 2 minutes.

Push Button Auto Repeat

Programming is easier with the push button auto repeat feature.

Extended Backup Time

The power failure backup time has been increased to 2 hours.

BUTTON FUNCTIONS

Clock	Press to set current day, hour and minute
DST	Press to change from Standard Time to Daylight Saving Time
Program	Press to set program days, start times, heating and cooling setpoints
Hold	Press to hold the current setting. The program will hold indefinitely or until RESUME is pressed.
Outdoor	Press to display the outdoor temperature (optional)
Mode	Press to select cool only, heat only, auto (cool & heat), emergency heat, or off
Fan	Press for continuous fan or auto fan
Resume	Press to exit the hold or override program or when programming is complete
▲ ▼	Press down or up buttons during programming and overrides to lower or raise setpoints and change the day and time

Selecting Fahrenheit or Celsius Display

Simultaneously press the ▲ and ▼ buttons to switch between Fahrenheit and Celsius.

Changing the Clock from 12 to 24 Hour

To change the time indicated from 12 hour to 24 hour, press and release the CLOCK button, then press the MODE button.

Adjusting the Clock for Daylight Saving Time

To adjust the clock for Daylight Saving Time simply press and release the DST button on your thermostat. This will cause the hour to advance by 1 and the DST icon will be displayed. Pressing and releasing the DST button again will cause the clock to fall back one hour and remove the DST icon.

UNDERSTANDING 5-2 DAY PROGRAMMING

It is recommended that you read and understand these instructions before you attempt to program your new thermostat.

The 5 refers to the 5 weekday period, Monday through Friday. The 2 refers to the 2 weekend days, Saturday and Sunday. Programming your thermostat involves selecting the temperature you want in your home and selecting the time you want it to be that temperature. Each time schedule is known as an event. An event ends at the same time that the next event begins so only a starting time for each event is required.

Your thermostat allows you to choose between a 2 event (Day and Night) or 4 event schedule. This is a DIP switch selectable option. For a more detailed description of event options refer to "DIP Switch Options and Functions."

Event = Morning ☀, Day ☼, Evening 🌃, Night 🌙
Event Time = the time the event starts
Event Setpoint = the temperature set during the event; each event can have only one heat and one cool setpoint

The Morning event is typically when you wake up and is the first event of the day. The Day event is normally set when you leave for work. The Evening event is usually set for when you arrive home. The Night event is set when you go to bed.

Each event will have two (2) temperatures: 1 heating temperature and 1 cooling temperature. The cooling temperature must be at least 2 degrees Fahrenheit higher than the heating temperature. The thermostat allows 1 program for Monday to Friday and 1 program for Saturday and Sunday. Complete the chart labeled "Set Your Personal Schedule" with your desired temperatures and time schedules before beginning programming.

To exit programming at any time press and release the RESUME button, or 2 minutes after pressing the last button the display will automatically change to the normal display.

PROGRAMMING THE THERMOSTAT

Setting the Current Day and Time

- Press and release the CLOCK button. The display will flash MO for Monday.
- Press the ▼ or ▲ button until the current day appears on the display.
- Press the CLOCK button to select the hour. The display will flash 12:
- Press the ▼ or ▲ button until the current hour appears on the display. Be sure the AM or PM corresponds to the proper time.
- Press the CLOCK button once again to select the minutes. The display will flash :00.
- Press the ▼ or ▲ button until the current minutes appear on the display.
- Press RESUME or wait for regular display to appear.

You have now set the current day and time on the thermostat and are ready to begin programming the details of the events and setpoints.

PROGRAM THE WEEKDAY/WEEKEND EVENT START TIMES AND HEATING SETPOINTS

The thermostat must be in AUTO mode for this procedure.

- Press the PROGRAM button; on the display you will see MO TU WE TH FR, representing the weekdays, a Morning ☀ icon, a flashing starting hour, and a heating or cooling setpoint.

- Select the desired starting time hour by pressing the ▼ or ▲ button. Be sure the AM or PM corresponds to the proper time.
- Press and release the PROGRAM button to select the minutes.
- Select the desired minute (if necessary) by pressing the ▼ or ▲ button (in increments of 10 minutes).
- Press and release the PROGRAM button. The heating or cooling setpoint will flash.
- Select the desired heating or cooling setpoint by pressing the ▼ or ▲ button.
- Press and release the MODE button to select the opposite heating or cooling setpoint.
- Select the desired heating or cooling setpoint by pressing the ▼ or ▲ button.
- Press and release the PROGRAM button.
- Continue until all the desired event start times and heating and/or cooling setpoints have been programmed.
For situations where only Morning and Night programs are required, refer to "Skipping an Event" to skip the Day and Evening events.
- Once you have set all of the weekday event start times, heating and/or cooling setpoints, press the PROGRAM button to move to the weekend events, and SA SU will be displayed.
- To program the weekend events simply repeat the steps used to program the weekday events.
To exit programming at any time press and release the RESUME button, or 2 minutes after pressing the last button the display will automatically change to the normal display.

Skipping an Event (2 Methods)

Your personal schedule may not require the use of all 4 events on a weekday. For example, if you wish to go from the Day event directly to the Night event, skipping over the Evening event, there are 2 methods you can apply:

- Press and release the PROGRAM button until you come to the day and event hour on the day that you wish to skip.
- Press and hold down the PROGRAM button and at the same time press and release the MODE button. In the time display area you will see " _ : _ " indicating that the event is skipped.
- If any two or more events have the same start time, the latest event in the day has priority.

Reviewing Scheduled Times and Setpoints

To review the program schedule press the PROGRAM button. Each of the scheduled events is displayed starting with the weekday start times and temperatures. To cancel your review, press the RESUME button, or wait 2 minutes for the thermostat to resume the display automatically.

Viewing the Outdoor Temperature (Option)

If your thermostat has been installed with an electronic outdoor remote sensor, you may view the outdoor temperature simply by pressing the OUTDOOR button. Upon releasing the button, the thermostat will once again display the indoor temperature.

Temporary Temperature Override

To temporarily change the scheduled setpoint during an event without affecting the program, press the ▼ or ▲ buttons to lower or raise the setpoints. The new setpoint will be retained for 3 hours and will not affect the programming schedule. You may return to the regular program schedule by pressing the RESUME button.

Temporary Temperature Override with Keypad Locked

With the keypad locked to prevent tampering you can temporarily adjust the setpoint by ±3°C or 6°F of the programmed morning setpoint without affecting the regular program. Press the ▼ or ▲ button to raise or lower the setpoint for a 1 hour period. This override may not be cancelled by pressing the RESUME button.

Constant Override

To maintain a temperature setting for an indefinite period of time, press the HOLD button. The word HOLD will appear on the LCD. The current scheduled setpoint will be maintained. To select a different setpoint, press the ▼ or ▲ button to raise or lower it. The last setpoint selected (scheduled or new) will be maintained continuously until the RESUME button is pressed.

Off Mode

To turn off the heating or cooling system, press the MODE button until the word OFF appears on the LCD. It will remain displayed until the mode is changed. The OFF mode prevents the system from being energized. **Avoid** using the OFF mode during extremely cold weather to prevent damage to the equipment from freezing.

Auto Changeover Mode

To set the thermostat to automatically switch from heating to cooling mode press the MODE button until the word AUTO and both the heating ◊ and cooling * icons appear on the LCD. The thermostat energizes the heating or cooling system based on the temperatures established for both modes.

SET YOUR PERSONAL SCHEDULE

This blank list is for your own use. Start by selecting your heat/cool temperature setpoints. Determine the times you want the temperatures to be active. Write in the desired times in the appropriate location.

5/2 Day programmable									
Event	Temperature Settings		Event Start Times						
			Sets all week day event start times the same.				Sets weekend event start times the same.		Week end Set points
	Weekday Set points		Mon	Tues	Wed	Thurs	Fri	Sat	Sun
Morning	Cool Heat								Cool Heat
Day	Cool Heat								Cool Heat
Evening	Cool Heat								Cool Heat
Night	Cool Heat								Cool Heat
Use this blank chart to determine your personal schedule. Write in the appropriate location your desired heat/cool temperature set points and the times to start for each day.			To not use a particular event, select the event, hold the PROGRAM button in at the hour or minute section, then press the MODE button. Four dashes will appear in the hour and minute section. 10:32 -- : --						

INSTALLATION INSTRUCTIONS

CAUTION
THIS DEVICE SHOULD BE INSTALLED BY A QUALIFIED TECHNICIAN WITH DUE REGARD FOR SAFETY, AS IMPROPER INSTALLATION COULD RESULT IN A HAZARDOUS CONDITION

Location

To ensure proper operation, the thermostat should be mounted on an inside wall in a frequently occupied area of the building. In addition, its position must be at least 18" (46cm) from any outside wall, and approximately 5' (1.5m) above the floor in a location with freely circulating air of an average temperature. You should avoid the following locations:

- behind doors or in corners where freely circulating air is unavailable
- where direct sunlight or radiant heat from appliances might affect control operation
- on an outside wall
- adjacent to, or in line with, conditioned air discharge grilles, stairwells, or outside doors
- where its operation may be affected by steam or water pipes or warm air stacks in an adjacent partition space, or by an unheated/uncooled area behind the thermostat
- where its operation will be affected by the supply air of an adjacent unit
- near sources of electrical interference such as arcing relay contacts.

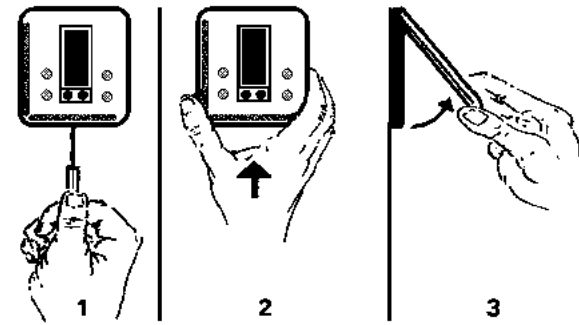

Removing the Thermostat from the Subbase

- Insert a flat blade screwdriver or a coin 1/8" into the slot located in the bottom center of the thermostat case and twist 1/4 turn. When you feel or hear a "click," grasp the case from the bottom two corners and separate from the subbase. *Some models require more force than others when separating due to the number of terminals used.*
- Swing the thermostat out from the bottom.
- Lift the thermostat up and off the subbase.
- Place the rectangular opening in the subbase over the equipment control wires protruding from the wall and, using the subbase as a template, mark the location of the two mounting holes. (Exact vertical mounting is necessary only for appearance.)
- Use the supplied anchors and screws for mounting on drywall or plaster; drill two 3/16" (5mm) diameter holes at the marked locations; use a hammer to tap the nylon anchors in flush to the wall surface and fasten subbase using the supplied screws. (Do not overtighten!)
- Connect the wires from your system to the thermostat terminals as shown in the wiring diagrams. Carefully dress the wires so that any excess is pushed back into the wall cavity or junction box. Ensure that the wires are flush to the plastic subbase. The access hole should be sealed or stuffed to prevent drafts from the wall affecting the thermostat.
- Before the thermostat is reinstalled on the subbase, install the optional clock/timer, indoor remote sensor and outdoor remote sensor, if used. Refer to the installation instructions supplied with each option. Also check the position of the DIP switches on the back of the thermostat.

WIRING DIAGRAM

Note: If the 24V(c) is not available from the equipment, the jumper may be removed and a separate 24V transformer must then be used to power the thermostat. To remove jumper (labeled JP1) from the printed circuit board, pull straight out.

This thermostat may be used with 24V DC. The negative side of the DC supply must then be wired to the 24V(c) terminal.

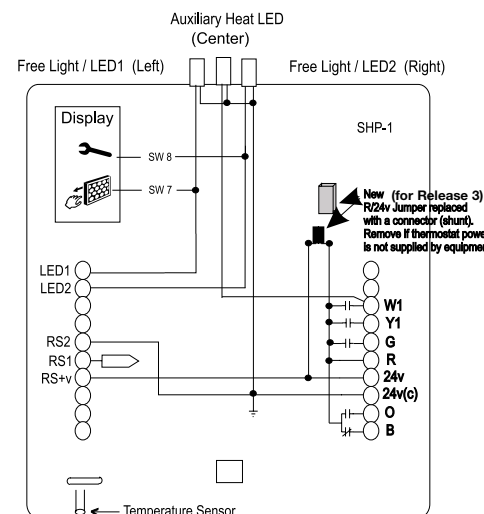

Outdoor Hi & Lo Temperature Balance Points (Heat Pump Only)

With the optional electronic outdoor temperature sensor, you can select the outdoor balance points to inhibit the auxiliary heat and/or compressor.

HibP – Press and hold the OUTDOOR button, then press the MODE button. **HibP** will appear on the display. Raise or lower the **HibP** by pressing the ▼ or ▲ button to set the temperature above which the auxiliary heat is locked out. Press the outdoor button while showing the **HibP** and the thermostat will switch to show **LobP**. **LobP** is used to lock out the compressor. Outdoor temperatures below the **LobP** will lock out the compressor. The factory **HibP** and **LobP** setpoints are +48°C and -48°C.

Replacing the Thermostat on Subbase

- Position the thermostat on the hinged tabs at the top of the subbase.
- Gently swing the thermostat down and press on the bottom center until it snaps into place.

Thermostat Cover Lock

You may lock the cover down to prevent unauthorized access to the thermostat by adding the plastic lock (included in the installation bag). Insert the plastic lock piece into the bottom of the mounted base. The ends of the lock piece fit snugly under the lock pins extending from the bottom of the mounted base. The tab in the middle of the lock piece extends down from the base. To release the locking mechanism, press the lock piece up and into the base while gently prying open.

Thermistor Mounting Instructions

When placing the thermostat on the backplate ensure the thermistor is not bent or misaligned. Ensure that the thermistor does not touch the thermostat case. The thermistor should be placed horizontal to the wall. Ensure the thermistor is not pushed upward into the case. The thermistor should be aligned so it is visible between the ribs on the bottom of the subbase.

TERMINATOR MOUNTING INSTRUCTIONS

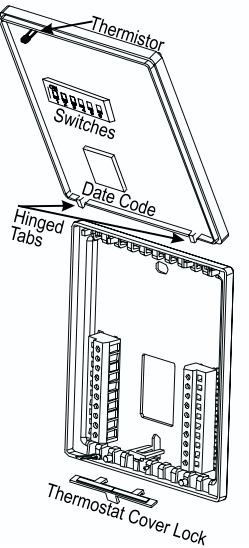
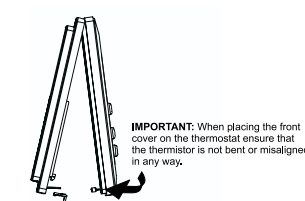

DETAIL A

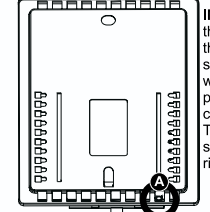

IMPORTANT: Ensure that the thermistor does not touch the thermostat case. The thermistor should be placed horizontal to the wall. Ensure the thermistor is not pushed upward into the thermostat case. The thermistor should be aligned such that it is visible between the ribs on the bottom of the backplate.

TERMINAL DESIGNATIONS

- W1**Energizes auxiliary heat as last stage heating or first stage emergency heat
- Y1**Energizes compressor #1 on a call for first stage heating or cooling
- G**Fan is energized with a call for heating or cooling or by pressing the FAN button
- R**Independent switching voltage
- 24V** . . .24 VAC hot and common to power the thermostat
- 24V(c)**
- O**Energizes the reversing valve continuously in cooling mode
- B**Energizes the reversing valve continuously in the heating & off modes
- RS2** . . .Use to connect up to 6 (SL-IDS) indoor and/or 1 (SL-ODT)
- RS1** outdoor remote sensor/s.
- RS+v** . .When connected the thermostat will automatically use the SL-IDS temperature sensor and not its own. Refer to the instructions included with the sensor
- LED1** . .Free status light when energized lights LED1. Also see Sw5
- LED2** . .Free status light when energized lights LED2. Also see Sw6 (Installer should identify what the LEDs are being used for.)